

PRISMCUT STAND ASSEMBLY INSTRUCTIONS

- 1) Starting from the bottom and working up, attach foot tips to foot. Then using the allen key and wrench provided, attach foot to leg using bolt (d). Repeat for other foot and leg.
- 2) Using screws (c) attach the two cross beams with top at front and bottom at back
- 3) Using bolts (d) attach the two roller brackets so that the brackets face the back of the stand
- 4) Using screws (a) attach both top brackets so that the brackets face inward

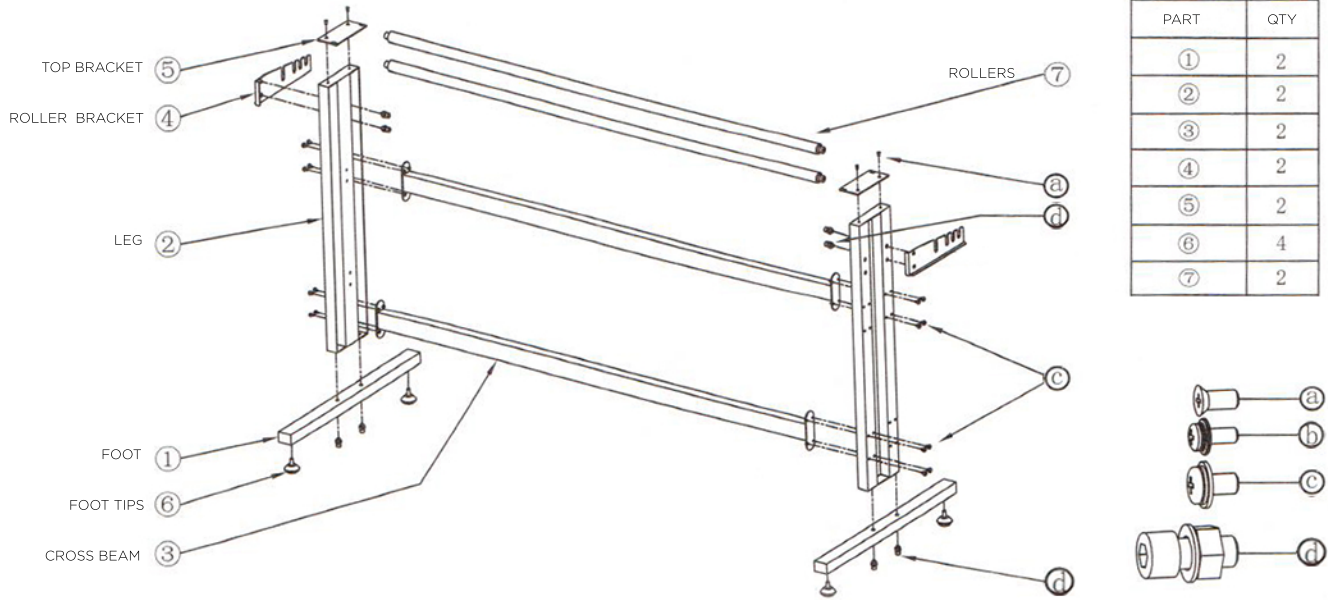

- 5) Unscrew the feet from the bottom of the PrismCut and use the same screws to attach the cutter to the stand. (or use screws (b))
- 6) Place rollers into grooves in the roller bracket. Rollers can be moved depending on size of roll

