

PrismCut Cutter/Plotter with WiFi USER MANUAL

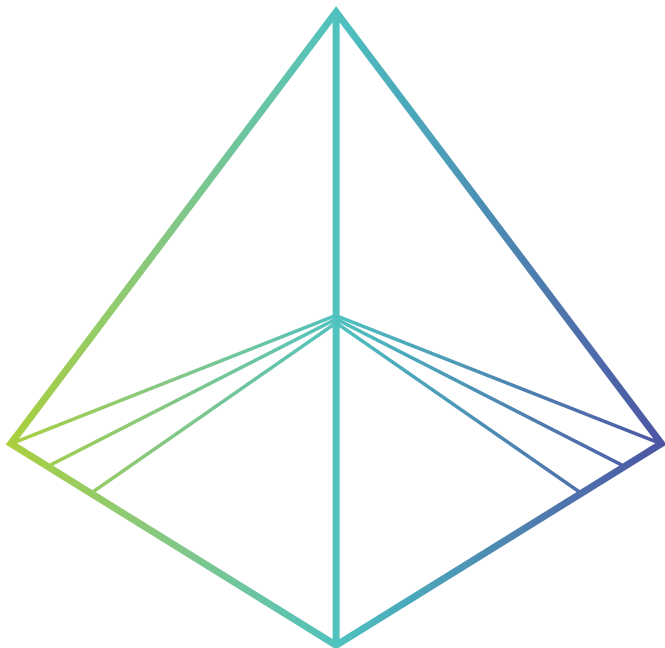
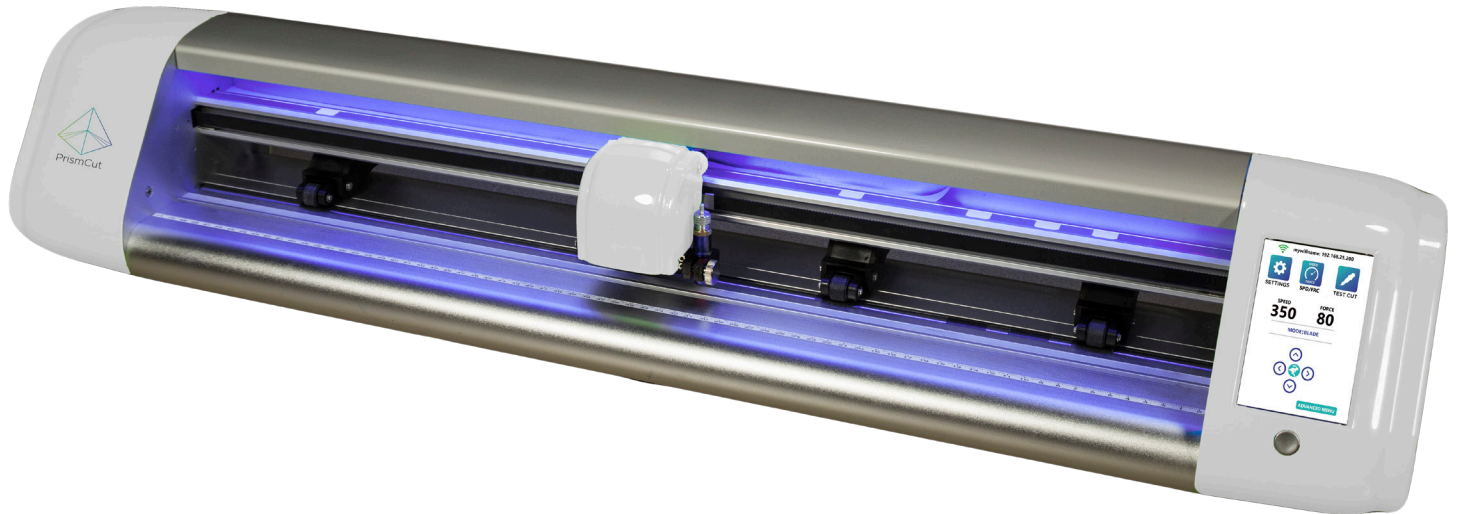

PrismCut

Version 1.9 Jan 2, 2020

SAFETY INFORMATION

IMPORTANT - READ THIS SECTION IN FULL BEFORE PROCEEDING

This product is designed for use as a cutter/plotter for vinyl and similar density materials. Use of the product in ways for which it was not designed can be very dangerous and will void the warranty

The product has fast moving parts and uses sharp blades. To avoid injury, keep fingers, hands, hair, loose clothing and other body parts away from the carriage head, rollers and other moving parts when the cutter is powered on.

Keep small children and pets away from the cutter whenever it is on.

Do not disassemble, repair, or remodel the plotter unless specifically instructed to do so by a qualified technician. Such action may cause electric shock or a fire hazard due to current leakage.

Use only the provided power supply and connect only to a properly grounded three prong wall outlet. Failure to do so may result in electrical shock or fire.

Do not use the cutter in an area where it will be exposed to water, rain, snow or other liquids that may get into the cutter. Fluids falling into the cutter may cause electrical shock.

If the cutter generates sparks, smoke, strange odor or otherwise functions abnormally, discontinue use, disconnect the cutter from the wall socket and contact the dealer from which you purchased the product. Never attempt to perform repair work yourself unless under the direction of the qualified service technician.

Do not use the optional accessories without first reading and understanding all the safety instructions for that accessory. Failure to do so may cause a hazard and injury to you or others.

TABLE OF CONTENTS

Section 1 - GETTING STARTED

- 1.1 Training videos.....page 4
- 1.2 Hardware setup.....page 4
- 1.3 Understanding vectorized vs. rasterized images.....page 6
- 1.4 Connecting your cutter via WiFi.....page 7
- 1.5 Software installation: Sure Cuts a Lot (MAC).....page 8
- 1.6 Software installation: Vinyl Master (Windows PC).....page 10

Section 2 - MAKING YOUR FIRST CUT

- 2.1 Overview of materials that can be cut.....page 12
- 2.2 Loading material in the cutter.....page 12
- 2.3 Using the pen tool to test your design.....page 13
- 2.4 Understanding blades and the blade holder.....page 13
- 2.5 Speed and Force settings.....page 14
- 2.6 Tips for achieving optimal results.....page 14
- 2.7 Connecting your cutter via USB cable..(optional)....page 15

Section 3 - ADVANCED TECHNIQUES

- 3.1 Moving from Basic Menu to Advanced Menu.....page 16
- 3.2 Advanced settings options.....page 16
- 3.3 Configuring Presets.....page 17
- 3.4 U-disk (cut from thumb drive without PC).....page 18
- 3.5 Contour cutting (print and cut with reg marks).....page 19
- 3.6 Using the (optional) embossing tool.....page 24
- 3.7 Using the (optional) engraving tool.....page 24
- 3.8 Using the (optional) laser attachment.....page 25
- 3.9 Connecting cutter via point to point WiFi.....page 25

Section 4 - MAINTENANCE AND TROUBLESHOOTING

- 4.1 Care and maintenance of your cutter.....page 26
- 4.2 Calibration/Settings.....page 27
- 4.3 Troubleshooting cutter issues.....page 29
- 4.4 Warranty and support.....page 31

Also, see PrismCut online video training to view the most current updates.

www.prismcut.com/videos

Section 1 - GETTING STARTED

1.1 Training videos

If you prefer to watch instead of read, you can find training videos that match the material presented in the manual at: www.prismcut.com/videos

1.2 Hardware setup

Your PrismCut cutter/plotter ships with the following standard accessories:



POWER CABLE



BLADE HOLDER



POWER ADAPTOR



PEN & REFILL



USB CABLE



BLADE SET
2 x 45 degree
1 x 60 degree

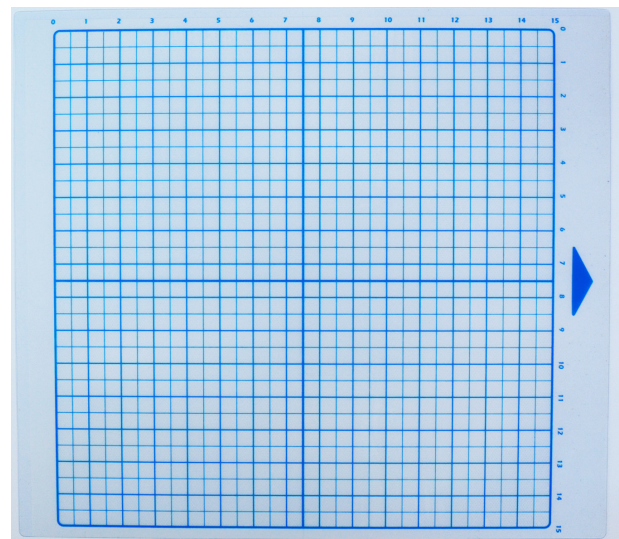

CUTTING MAT
15" x 15"

Optional accessories available for purchase are described in Section 3 of this user manual

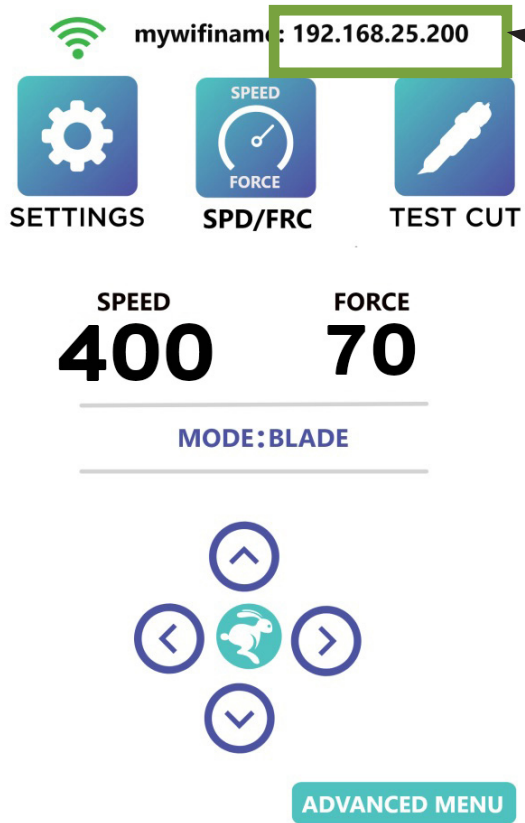
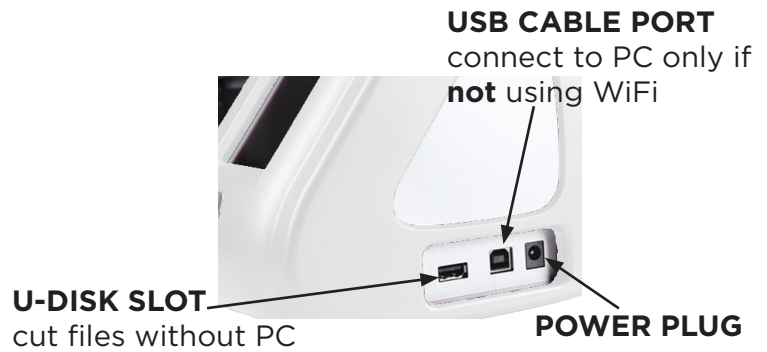
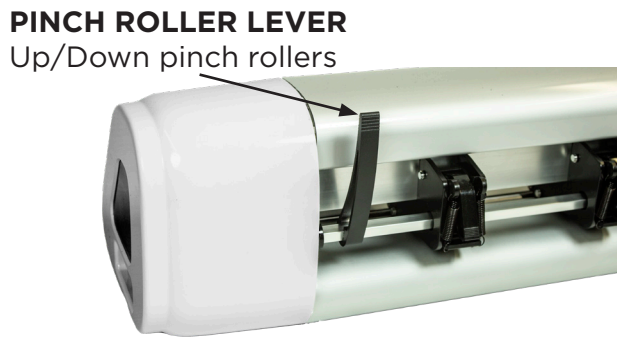
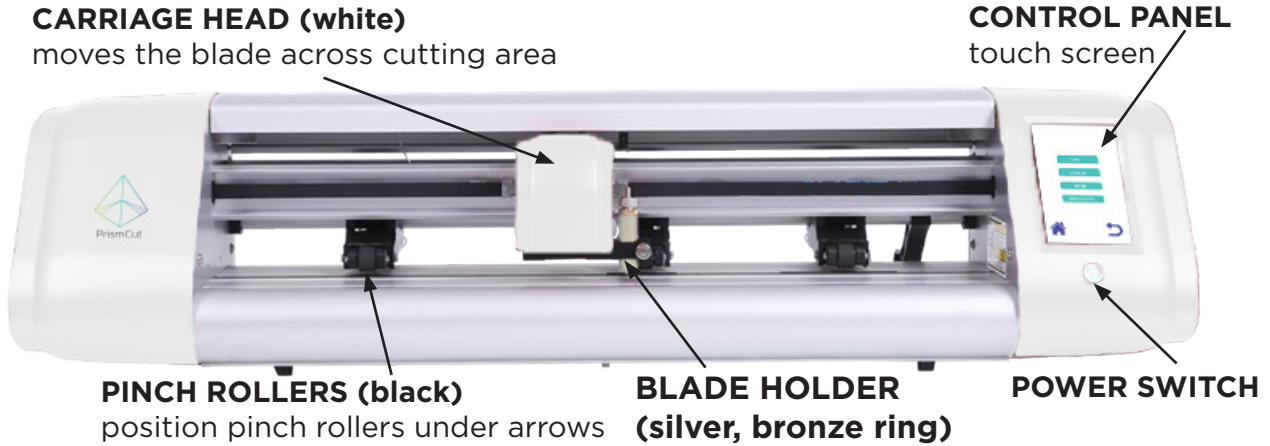

The IP address will display at the top of the cutter's screen after you have connected to your home WiFi (see Section 1.4).

The IP address must match on your cutter and your computer for wireless communications to work.

If the top line of your cutter screen shows "HI-LINK_XXX" you are **not** yet connected to your home WiFi. Click on the **SETTINGS** icon and then go to the **WIFI** menu to connect the cutter to your home WiFi.

1.3 Understanding Rasterized vs. Vectorized images

There are two main ways that an image can be represented:

1) ***Rasterized images*** are composed of individual dots (pixels) as you might find in a photograph. These images have filename extensions such as .JPG .PNG .GIF

2) ***Vectorized images*** are made from lines (paths) between points as you might find in a scaled vector graphic drawing. These images have filename extensions such as .AI .SVG .EPS

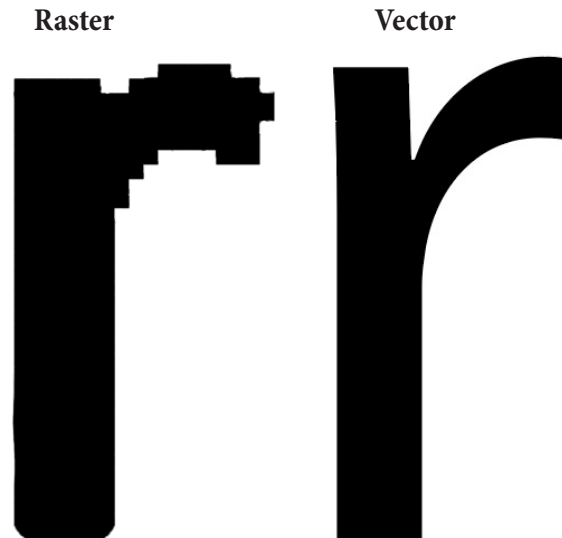

If you try to zoom in and enlarge a (rasterized) photo, you will eventually see the individual dots (pixels) and the edges will not appear smooth. With vectors this is not a problem and you can enlarge the image to any size you want

Your PrismCut requires vectorized artwork. If you are using Vinyl Master or Sure Cuts a Lot as your design software program, new designs you create will be in vector format. For raster images, both software programs have vectorization and tracing features that allow you to import many different types of pixel images that can be converted to vectorized artwork. For images with strong contrast between the subject and the background typically work best. Please consult the training materials for Sure Cuts a Lot 4 or VinylMaster to use the vectorization features in each software.

1.4 Connecting your PrismCut cutter via WiFi

WiFi is the recommended connection method for your PrismCut. Other than the power cord, there is no need for any other wires if using WiFi communications.

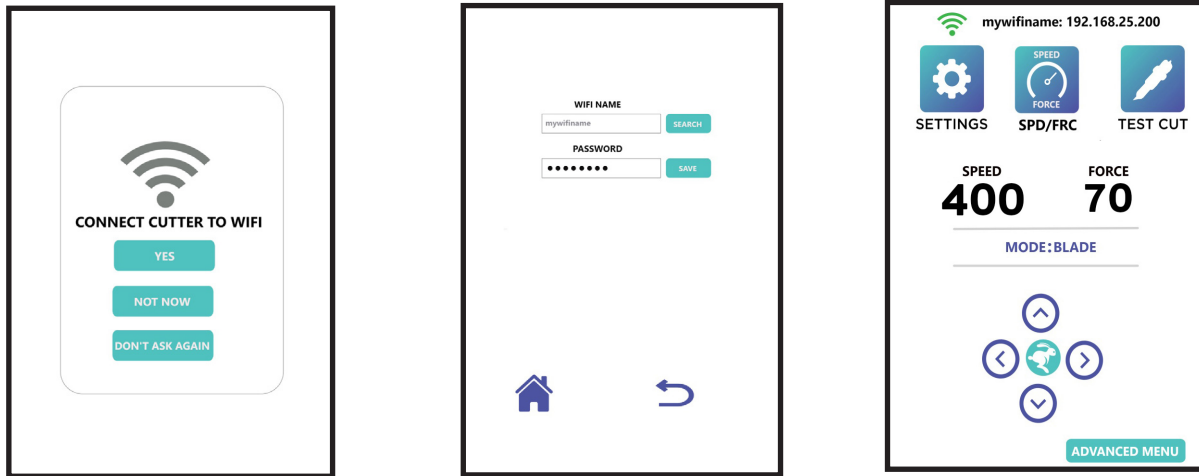

When your PrismCut powers on for the first time, you will see a message asking you to connect it to your home WiFi (same as you would connect your laptop or wireless printer). Before powering on, make sure you know the name and password of your home WiFi router and that you are in range of the WiFi signal. If you connect via WiFi, there is no need to connect any other wires, except power.

Press the SEARCH button and the PrismCut will display the name of nearby WiFi routers. Select your router from the list and enter your password. (Sometimes the password is printed on a label that is on your home router). It should be the same WiFi password you use to connect your laptop to your home WiFi.

Once connected, your PrismCut will display your router name and an IP address at the top of the cutter's home screen. The IP address on the cutter and the IP address used by the software program in your computer **must be the same** in order for both sides to communicate.

If the top line of your cutter's screen says "HI-LINK_XXXX" you are **not** yet connected to your home WiFi router. On your cutter screen look under SETTINGS->WIFI to connect the cutter to your WiFi using the same WiFi password you use to connect WiFi for other home devices.

For advanced users, it is possible to configure the PrismCut to connect via point-to-point WiFi as might be the case if you are selling at an outdoor craft fair where there is no internet. This technique is discussed in section 3.9 of this manual and is intended for advanced users.

1.5 Software setup: Sure Cuts a Lot (MAC)



If you purchased Sure Cuts a Lot 4 Pro with your cutter, you should have a card that says Sure Cuts A Lot on the front. The back of the card contains a software serial number (see the red oval below). You will need this software serial number to register and download your Sure Cuts A Lot software. Note that the software serial number is different than the hardware serial number of the cutter itself.

DO NOT LOSE THE CARD OR ACTIVATION CODE - KEEP IN A SAFE PLACE

Download software at: <http://www.craftedge.com/register/scal4pro>

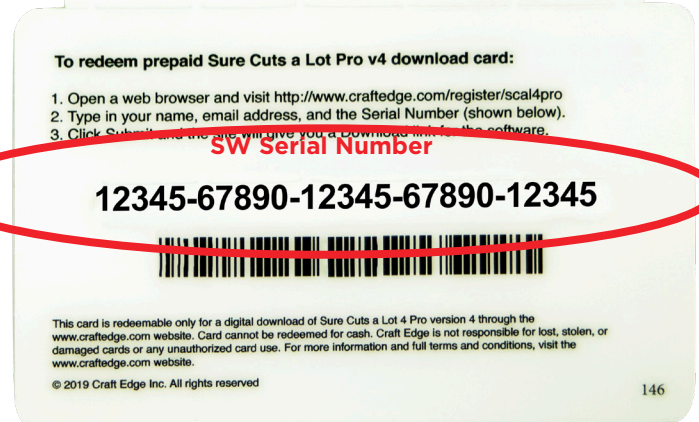
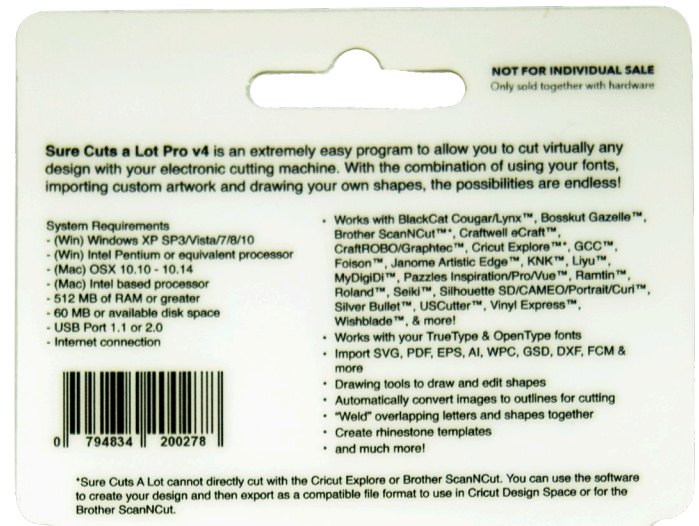
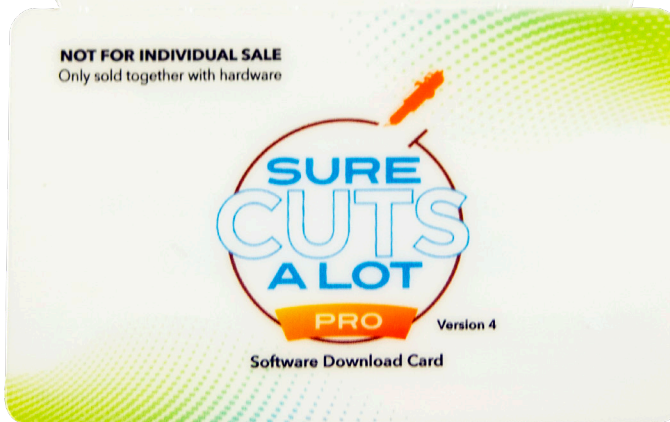
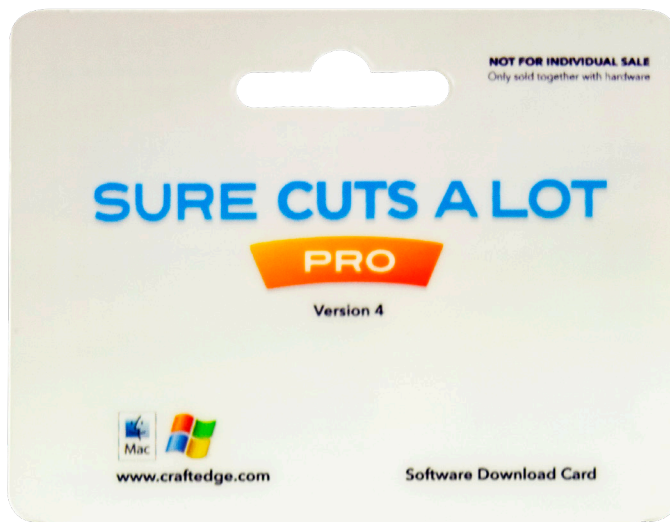

Follow the instructions on the card that point you to the link where to enter your name, email address and the Software Serial Number from the card. You will then be able to download the software. Install the software on your computer as you would any other software.

Write down the email that you used for this activation as it may be needed in the future!

Sure Cuts a Lot (MAC) - configure WiFi connection



WiFi is the recommended communication method for your MAC.

In Sure Cuts a Lot, click on the Cutter icon (red circle) to open the Cut Settings menu. Select Model=PrismCut, Connection=TCP/IP and enter the IP address that will appear at the top of your cutter's home screen after you connect the cutter to WiFi. The IP number on the cutter and the IP number on the computer **must match** for WiFi to work.

(note: If you see HI-LINK_XXXX on your cutter it is **not** yet set up for WiFi)

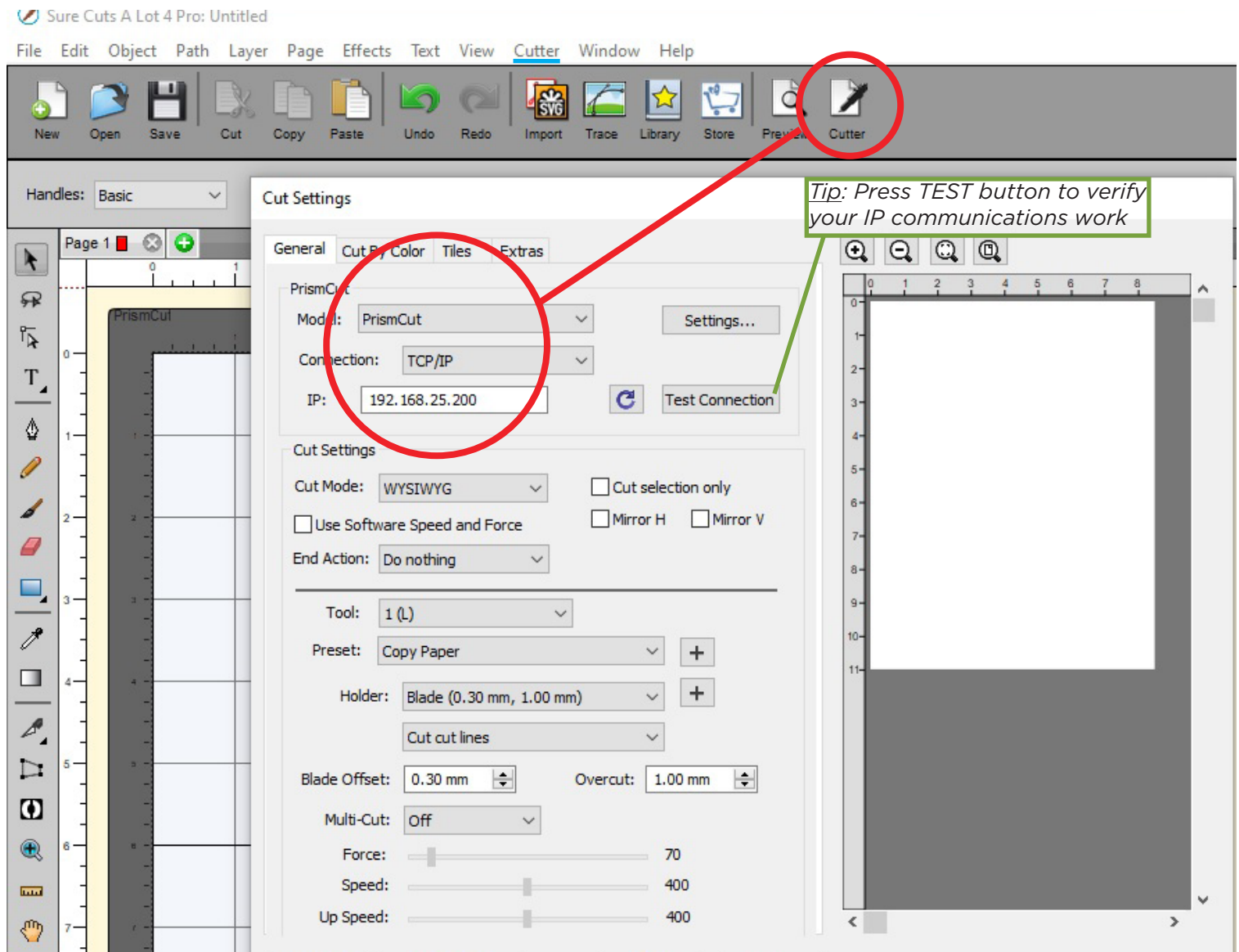

If you do not see PrismCut as a selection under Model, look at the top line of your MAC screen and select [Cutter](#)->My Cutter->Manage Cutters and add PrismCut

Click on Help->About Sure Cuts A Lot 4 Pro to ensure that your software version is 4.080 or higher. Otherwise you may need to download and re-install the most current version of SCAL4 software. Older versions of software will not yet have the driver.

1.6 Software setup: Vinyl Master (Windows PC)



If you purchased Vinylmaster with your cutter, you will have a card with an activation PSN to allow download of the software for a Windows PC.

DO NOT LOSE THE CARD AND ACTIVATION CODE (PSN) - KEEP IN A SAFE PLACE

Download Vinylmaster software at: <https://fcws1.com/info/vmlinks.php>

Web Links Page

Manage your Software and/or Product Serial Number (PSN):

- Download Software** - Visit the download page to download the software and/or the extras
- Upgrade Cart | Login - View pay over time options and learn about upgrading to VinylMaster LTR | PRO | DSR
- Find PSN - Search for your PSN if you have lost or forgotten it
- Clear PSN - Remove old activated computers from your license to allow activating another computer
- Activation FAQ - Information on how to activate/deactivate the software
- Legacy Drivers - Search for and download legacy (older model) cutter drivers

After downloading, click on the file you downloaded. Follow the prompts to install the software

On your Windows PC within VinylMaster software, click on shuttle icon and select Vinyl Spooler

VinylMaster Ltr V4.0 - [*Untitled.vDoc]

File Edit View Layout Arrange Objects Effects Images Text Curves Colors Tools Window Help

Vinyl Spooler

Submit Feedback...

Gateway...

Settings/Preferences...

Vinyl Spooler

File Edit Cutter Settings View System Calibration Help

Filter by Job Filter by Color Show All Jobs Most Recent Job

Color	Job Name	J...	Qty	Preview
+	Current			
+	Custom			
+	Done			
+	Repeats			
+	Deleted			

Click on the Connection tab within the Vinyl Spooler menu to display cutter Connection Settings. In Current Vinyl Cutter section click on the pull down menu for Current Cutter and select PrismCut. In Connection Method section click on the pull down menu for Port Type and select Windows Port.

(if you do not see PrismCut as a pull down menu option for Current Cutter, see Troubleshooting on page 30)

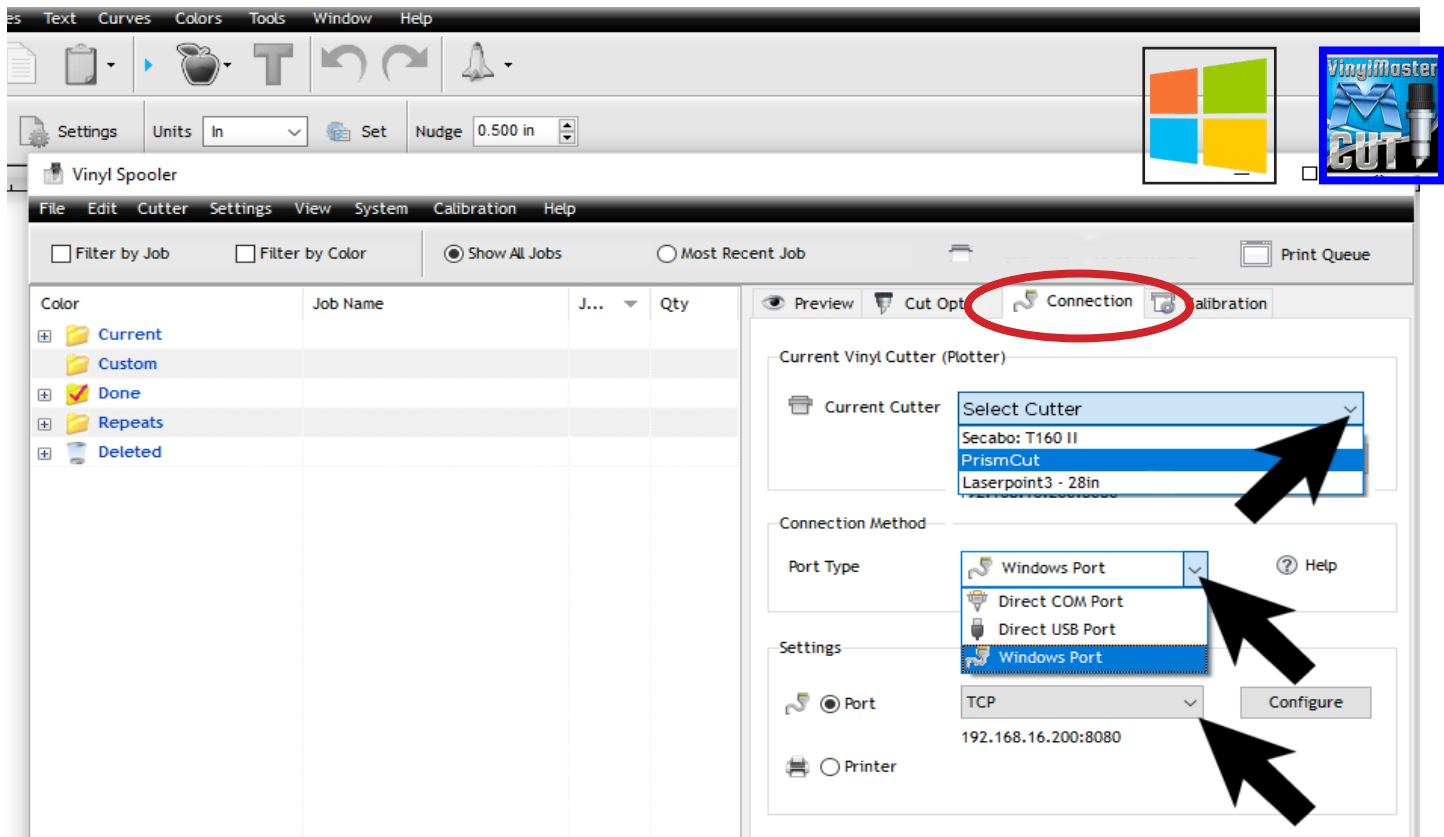

In Connection tab Settings section click on the Configure button to open the TCP/IP Port Settings menu. In TCP/IP Settings menu enter the IP address that appears at the top of your PrismCut cutter's home screen. The IP address (starts with 192.168.....or 172.... or 10.....) must be the same on both cutter and PC to work. Ignore the port number (leave at 8080) since this is not part of the IP address.

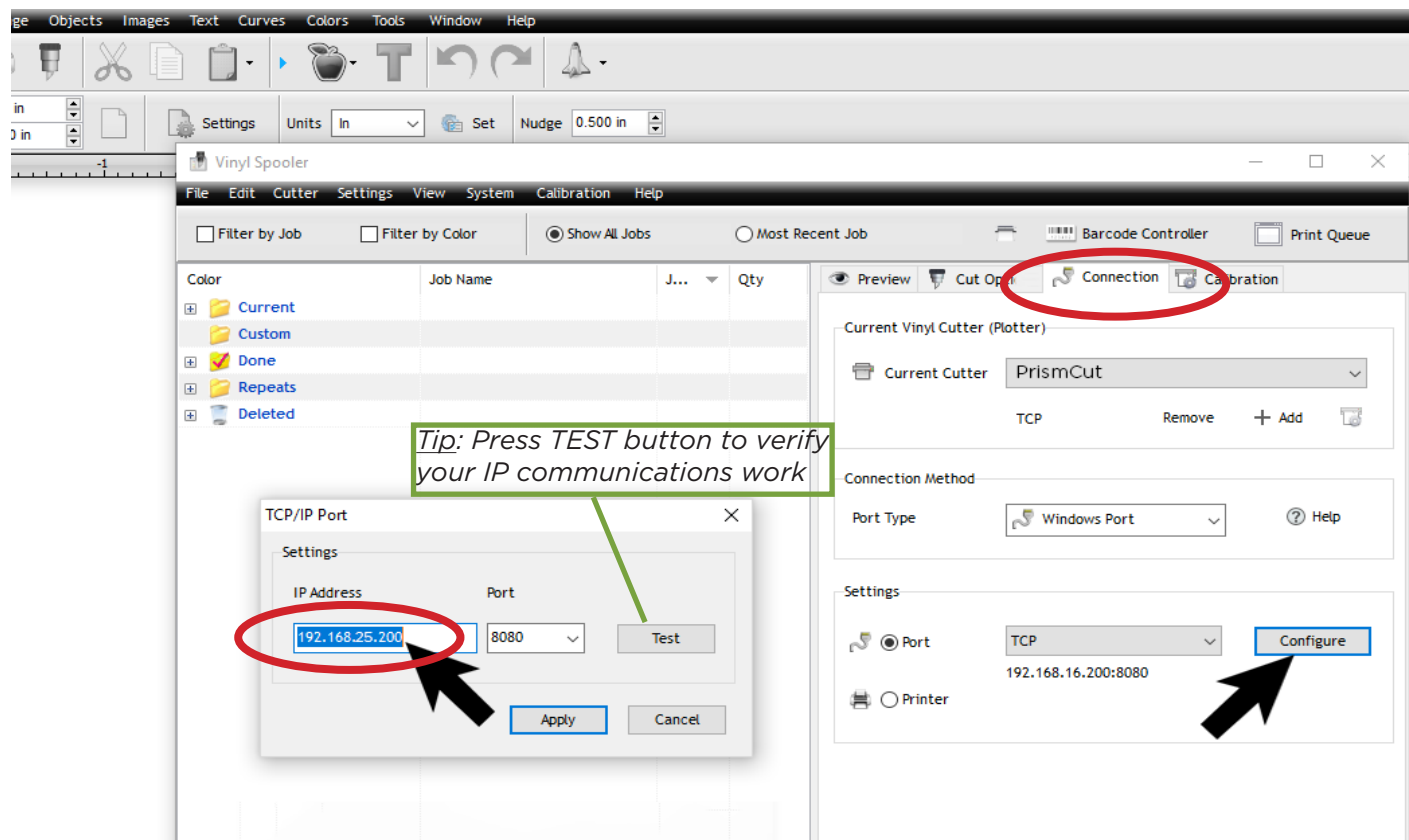

Section 2 - MAKING YOUR FIRST CUT

2.1 Overview of Materials That Can Be Cut

There are lots of different materials you can use with your PrismCut including: paper, cardstock, photos, vinyl, stencil, poster boards, labels, fun foam, balsa wood, leather, acetate, styrene, chipboard, shrink film and much more. The key thing to consider is how dense the material is. Some very dense materials such as metal, sandblast mask, magnet etc. are not recommended as they may yield unsatisfactory results. As a general rule you should be able to cut any material that is less than 2 mm thick and at the approximate density of 1 g/cm³.

Always start with a test cut, especially when changing materials

You can etch designs onto metals and other dense materials or make creases on cardstock, leather etc. by using the optional etching and embossing tools.

2.2 Loading material in the cutter

Materials that have no backing (such as thin card stock) should be placed on the cutting mat and then loaded. Materials such as vinyl, which have a backing, can be placed directly in the PrismCut without using the cutting mat.

First, make sure the pinch rollers are lined up directly above the grit rollers on the axle. The black arrows on the cutter are there to help identify the correct pinch roller positioning. Place the material to be cut in the PrismCut so that the rollers are at the edges and will not touch the design as it is being cut. In some cases, such as with wide jobs it cannot be avoided and rollers will go over the design, however this is typically not a problem even if the rollers touch the design.

Lower the pinch rollers by raising the pinch roller lever at the back of the cutter. Note that the small levers on each pinch roller should be down in most cases, and only positioned up when extra pressure is needed.



When cutting, the vinyl will move outwards from the cutter towards you. In most cases, vinyl on rolls is loaded from the back of the cutter and other materials on the cutting mat can be loaded from the front of the cutter.

2.3 Using the pen tool to test your design

Before cutting valuable material, it is recommended that you first work with the pen tool on some blank paper. The pen tool will follow the same path that the blade will so you can be sure you will be cutting the exact design you thought you would be cutting. Simply place the pen tool in the blade/tool bracket on the carriage head, tighten the screw and you are ready to start. Note that the pen has a small cap on the tip that needs to be removed prior to use.



2.4 Understanding blades and the blade holder

Your PrismCut ships with two 45 degree (red tip) and one 60 degree (blue tip) blades. For most needs the 45 degree (red tip) blade is best. 60 degree blades are only required for thicker materials or when a higher degree of precision is needed. Note that 60 degree blades might get dull sooner or chip easier. For very thin materials and thin fabrics a 30 degree blade is recommended (yellow tip, purchased separately). You may need to place thinner materials on the sticky part of the cutting mat so they do not tear as easily when being cut.

The diagrams below show how to insert a blade, as well as the correct way to set the blade depth so that it cuts all the way through the top layer but only lightly scratches the backing layer.

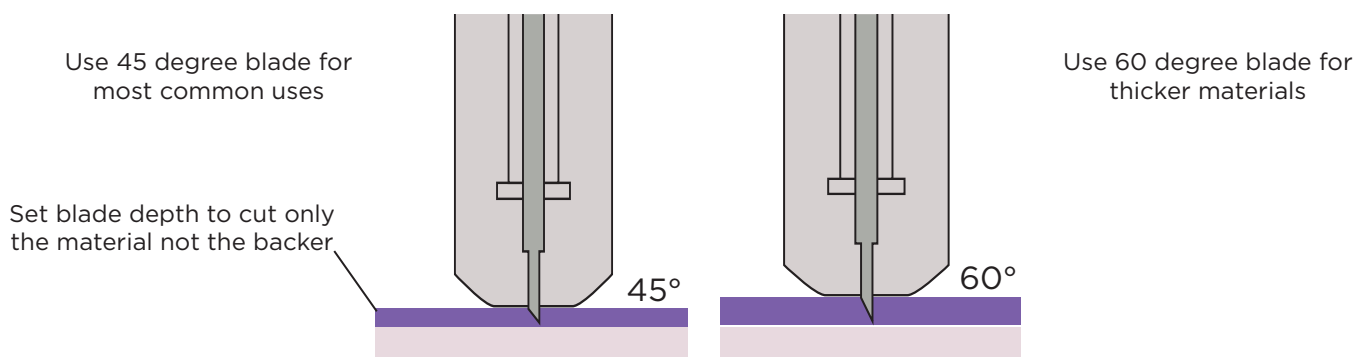
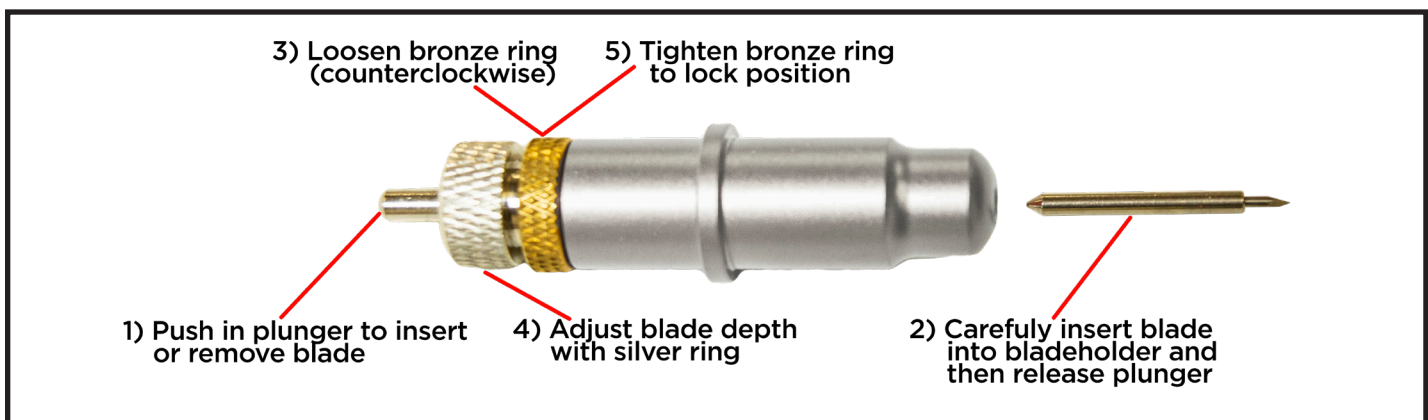

2.5 Speed and Force settings

A good starting value for speed is 400

A good starting value for force is 70

To achieve more precise results, you should start with moderate speed and force settings (400 and 70) and then increase speed only if the job is less complex. Increase pressure if the cut is not making it all the way through the top layer of the material being cut. As a general rule, you will try increasing pressure before you extend the blade length. Note that different brands of the same material (eg. glitter) may need to use more or less pressure, depending on the specifics of each manufacturer's brand.

Refer to section 4.2 for additional speed/force values for various materials

2.6 Tips for achieving optimal results

- Use a short blade depth. In most cases the blade should be exposed no more than 1/2 the thickness of a credit card. New users tend to expose too much blade. The idea is to cut through only the top layer of the vinyl and to leave the backing layer with only minimal scratches. This allows you to weed the top layer off the backing easily. If corners or small detail do not cut all the way through, consider increasing the force before extending the blade depth. You only need to extend the blade depth or use the 60 degree (blue tip) blade for thicker materials.
- Align the pinch rollers so that they are under the guide arrows. The pinch rollers must align with the gritted sections on the bottom roller. Note that the levers at the top of each individual pinch roller should be in the down position unless extra strong roller pressure is needed.
- The cutting mat is used when cutting materials that do not have their own backing. Place your material on the cutting mat so that the pinch rollers roll on the mat, not the material. Move unused pinch rollers out of the way so they don't touch the parts of the material being cut. Use a brayer roller to flatten your material on the sticky part of the cutting mat or tape the edges of thicker materials to the cutting mat. For wider jobs it sometimes cannot be avoided and the pinch rollers will need to roll over areas of the material being cut. Typically this is not a problem. If cutting very thick materials you may want to consider purchasing a thinner mat.
- When cutting long pieces of material it is important to carefully position the material so that it is completely straight and doesn't drift to one side when cutting.
- Cutting tiny lettering and small details from heat transfer vinyl (HTV) is best achieved by using a 60° blade at a relatively low force setting so that the HTV backing is barely scratched during the cut. However be sure that the blade is able to cleanly cut all the corners. To help weeding, place the HTV on the warm (but not hot) bottom platen of a heat press which will help loosen the vinyl from the backer.

2.7 Connecting your PrismCut cutter via USB cable (optional)

There is no need to connect your PrismCut via USB cable if you are already connecting via WiFi. USB is provided as a backup in case you are in an area that is not served by WiFi. WiFi is the recommended connection method.

To connect via USB, connect one cable end to USB cable port on the cutter and connect the other cable end to an available USB port on your computer.

Sure Cuts A Lot (MAC) users can enable USB communications by clicking on the Cutter icon to open the Cut Settings window and selecting USB and Auto Detect as the Connection method and Port type.

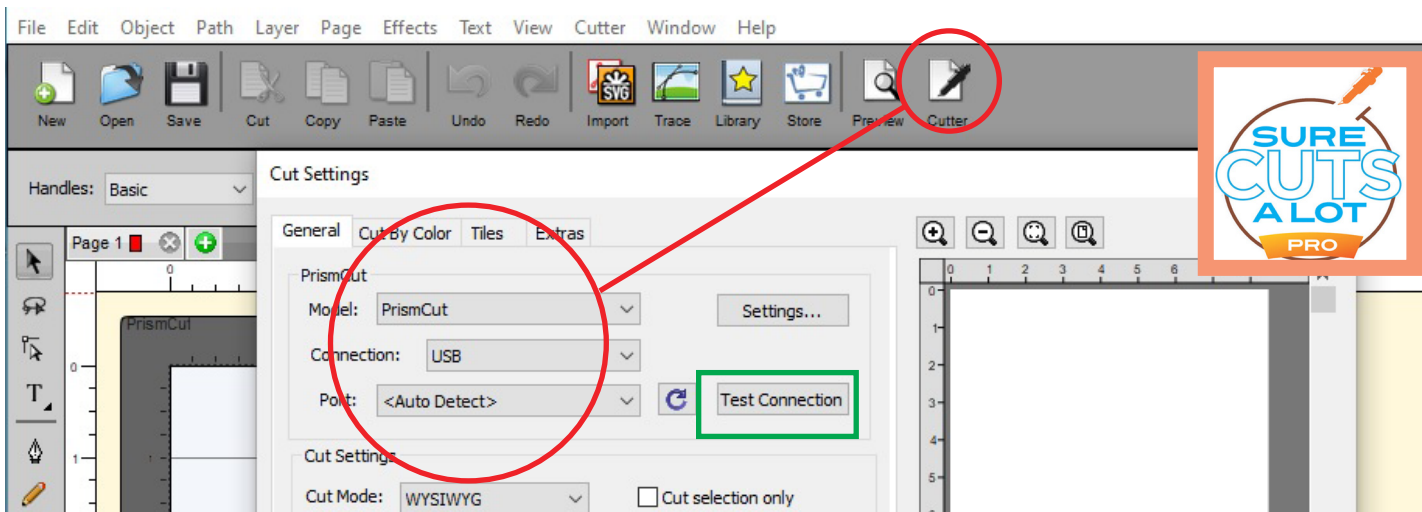

VinylMaster (Windows) users can enable USB communications by clicking on the Shuttle icon and then select the Connection Tab within the VinylSpooler window. Under Connection method select Direct USB Port from pull down menu

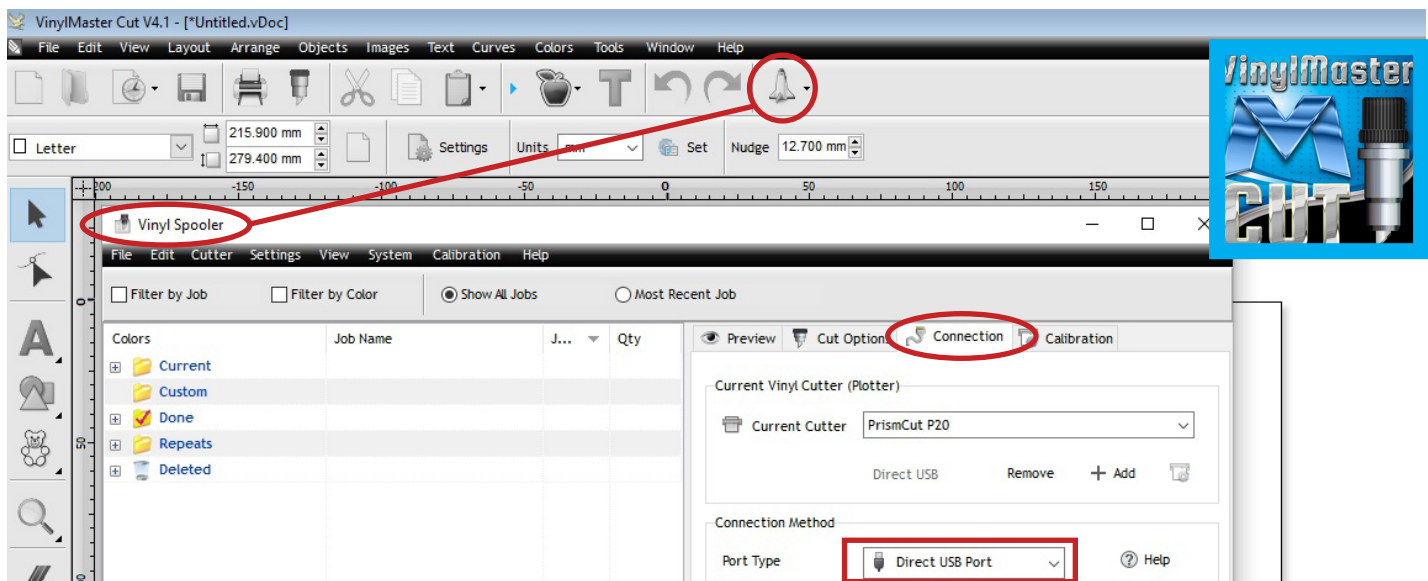

Section 3 - ADVANCED TECHNIQUES

3.1 Moving from Basic Menu to Advanced Menu

This is as simple as pressing the Advanced Menu button at the bottom right of the PrismCut home screen. Perhaps more important, is knowing that you can always get back to the Basic Menu if you prefer a more minimalist approach to cutting. You will see that icons that appear in both menu modes (eg. Settings) may now contain more options in the Advanced Menu mode.

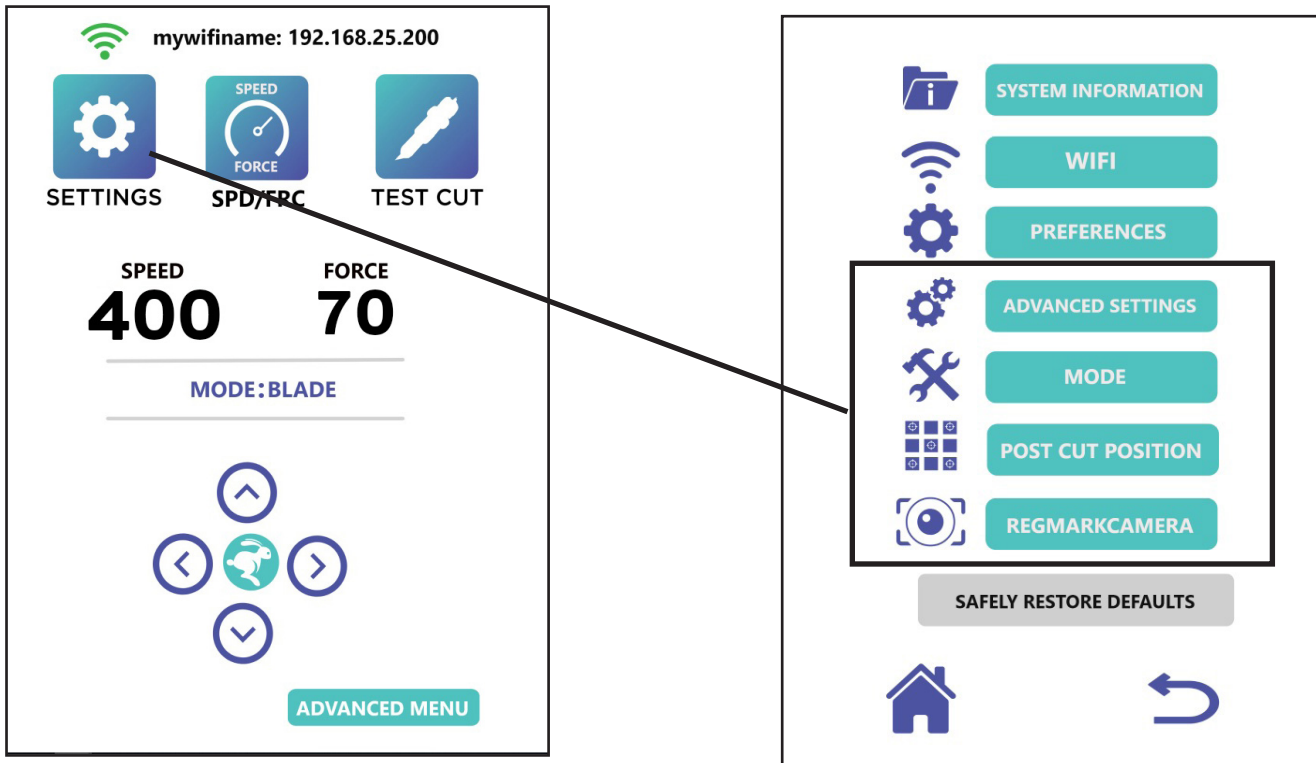

3.2 Advanced settings options

Under the settings icon, you will now see an option for Advanced Settings.

- *Move right on power* will cause the carriage to go home when powered on.
- *Inverted Y axis* swaps the media feed direction of the up/down arrows
- *RegMarkTracking* is used when contour cutting (see Sections 3.4 and 3.5)
- *Calibration* is used when servicing the cutter. (see Section 4.2)

3.3 Configuring Presets

Presets are stored speed/force settings that you can rename with the product names or job names you use most often. The PrismCut will display the name of the preset it is using so you know that the settings are exactly as you wanted them. The Presets icon appears on the Advanced Menu Home Screen.

Press the Presets icon to see a list of presets and highlight the circle beside the preset you want to work with. To edit preset values or to edit the name of the preset, just press the EDIT PRESET button, make your changes and press SAVE.

To give your preset a custom name, press the RENAME key which will bring up a keypad. Press a key multiple times quickly to cycle to other letters if the keypad displays more than one letter.

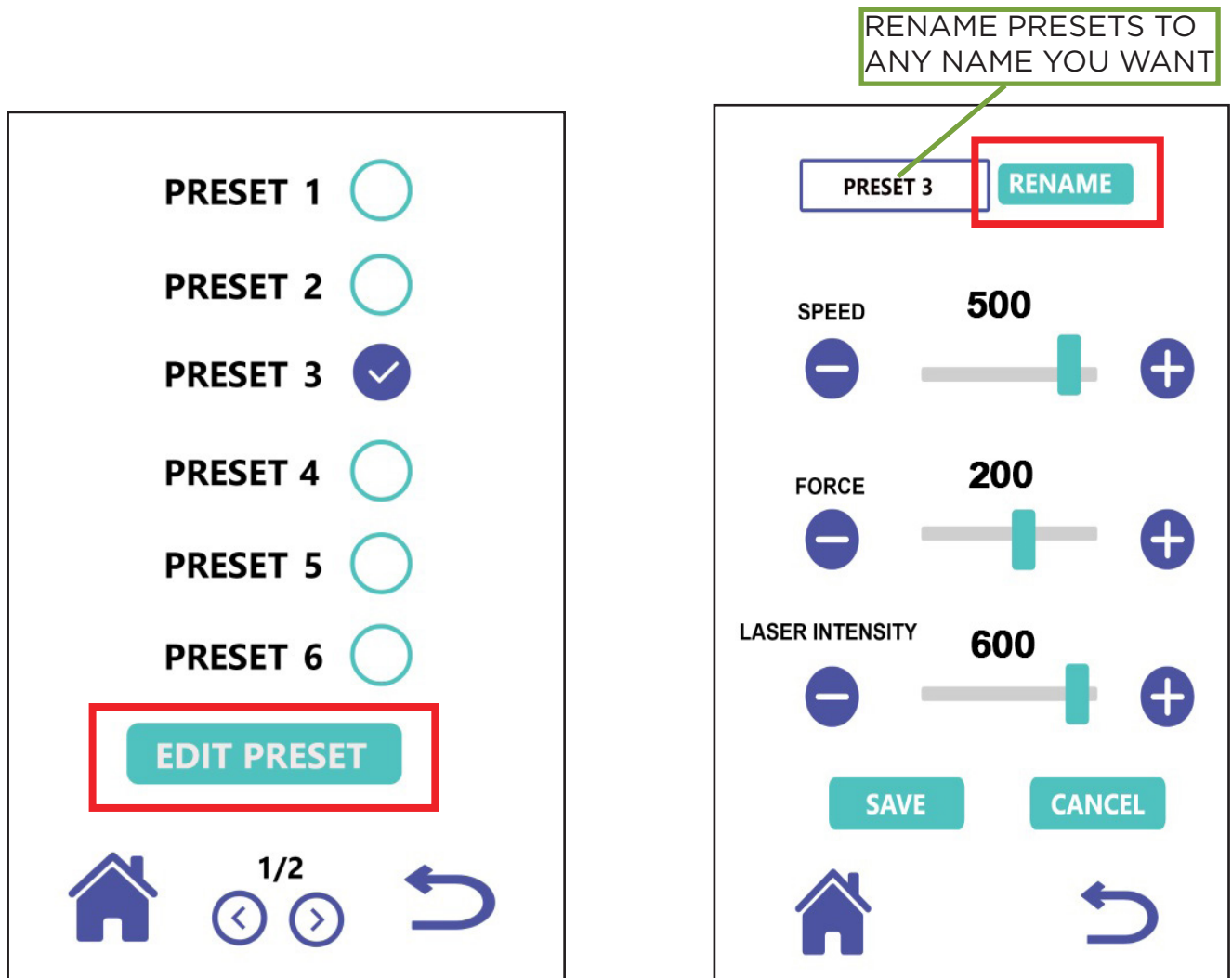

3.4 U-disk (cut from thumb drive without PC)

Your PrismCut can cut jobs stored on a U-disk, also known as a thumb drive, without being connected to a host computer (purchase thumb drive separately). First, save/export your design to a 32GB or less thumbdrive in .PLT format.

SCAL 4 Pro: File->Export, then save as file type HPGL Plotter (.plt)

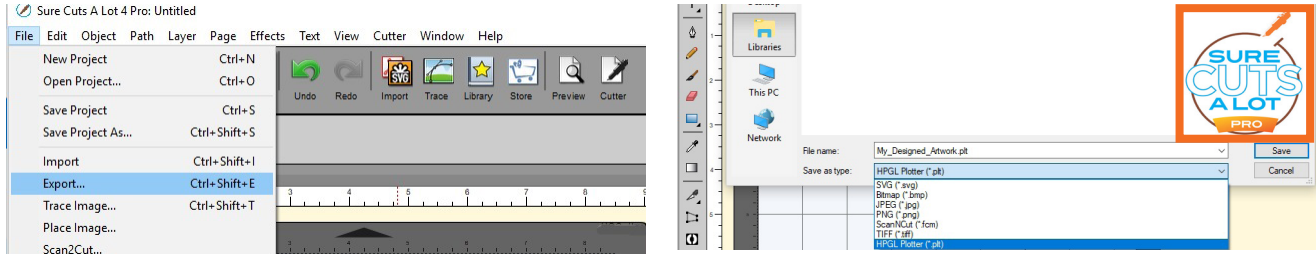

Vinylmaster: Within the preview tab of the Vinyl Spooler

Check the box “Save as PLT” to toggle button from Cut Now to Save

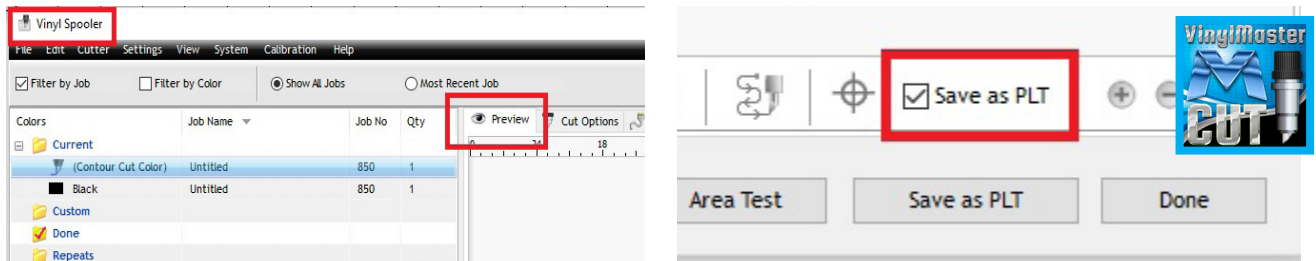

Once you have exported your .PLT file to a [32GB max] thumbdrive, connect the thumbdrive to the USB port of the PrismCut and click on the U-drive icon on the home screen of the PrismCut. Scroll to the desired filename and click on it to load it into the PrismCut memory. You have the option of cutting multiple copies of your design at once by enabling the multiple tiled copies option which allows you to set up a grid and add additional registration marks. Otherwise just ignore the Set Tiled Copies option and print only one copy of your design at a time.

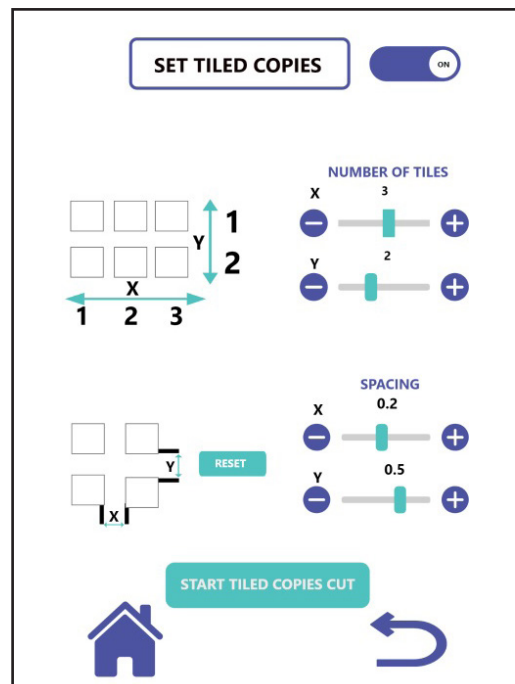
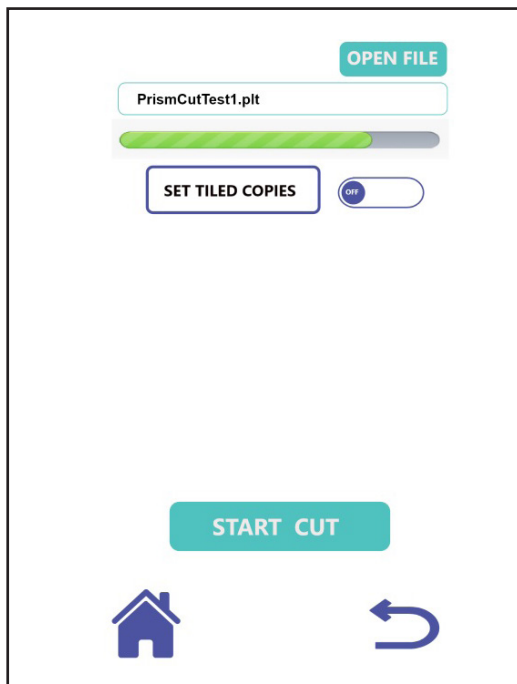

3.5 Contour Cutting (Print & Cut) with registration marks

Contour Cutting (also known as Print & Cut) involves printing a design that has special registration marks in the outside corners. The registration marks are read by the cutter to allow precise cutting around the outside contours of the design. Common uses for contour cutting are to create peelable stickers or cutting out printed designs from printable heat transfer vinyl.

IMPORTANT: Always print contour cut jobs at actual size - some printers will be set to “fit to page” as default which will cause the job to not cut correctly.

You may see the term ARMS (Automatic Registration Mark Sensor) being used to refer to Contour Cutting. This is just a more technical term for achieving the same type of results as Contour Cutting, also known as Print & Cut.

In order for the software to be able to find the outside edges of your artwork and draw a contour, ideally you want to use vectorized files with no background such as SVG/AI/EPS vector files.

If working with pixel based images such as photos, JPEG files with a background or images with a solid white background, you should remove the background and save as a PNG whenever possible. In general, images with a complex background are likely to need modification to remove the background prior to proper vectorization and contour cut use.

PDF files can contain both vector and raster images, but usually these are on separate pages within a PDF document. Zoom in on the image to see if it starts to pixelate when magnified (raster) or keeps lines smooth (vector).

Refer to section 1.3 on page 6 of this manual to learn more about pixel based and vector based images.

Before creating your first contour cut, you may have to calibrate the camera, but this only needs to be done once. Refer to the Calibration instructions in Section 4.2 of this manual if your camera has never been calibrated.

Another advanced contour cutting feature is RegMarkTracking which means adding additional registration marks in addition to the 4 corners to help keep alignment straight over a very long job run length. It is even possible to use the RegMarkTracking in conjunction with Udisk so you can run repeat jobs without a PC being attached.

3.5.1 Contour Cutting / Print & Cut with Sure Cuts A Lot 4 (MAC)



Use File->Import when working with vector files (SVG, AI, EPS etc.)
 Use File->Place_Image when working with raster files (JPEG, TIFF, PNG etc.)
 Once you have put your image on the design mat, go to File->Trace_Image.

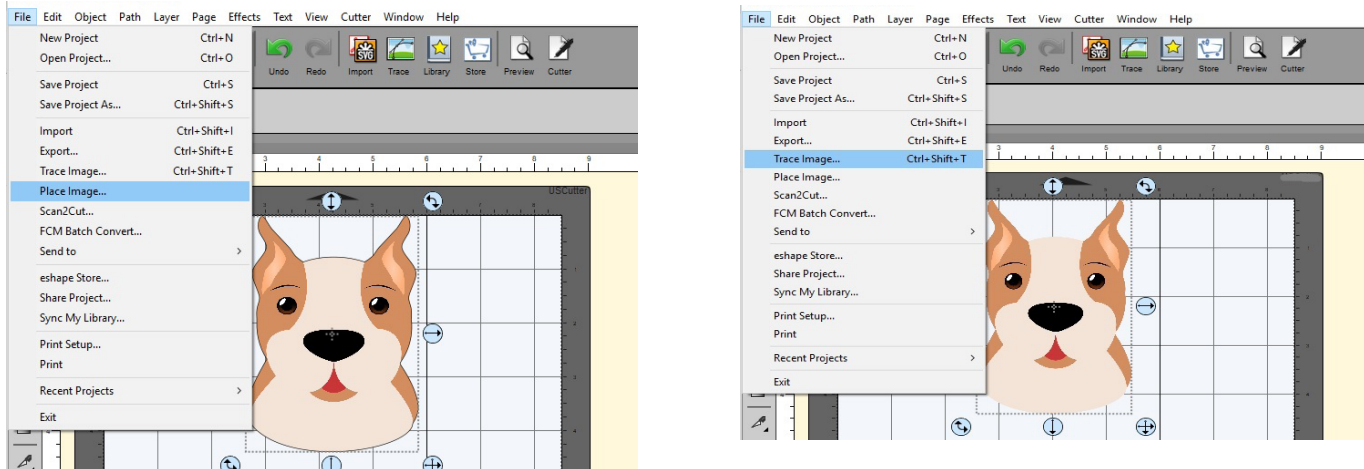

The Trace_Image pop-up window will appear. Make sure to check the box to “Add Layer for Print & Cut” and then press OK to continue.

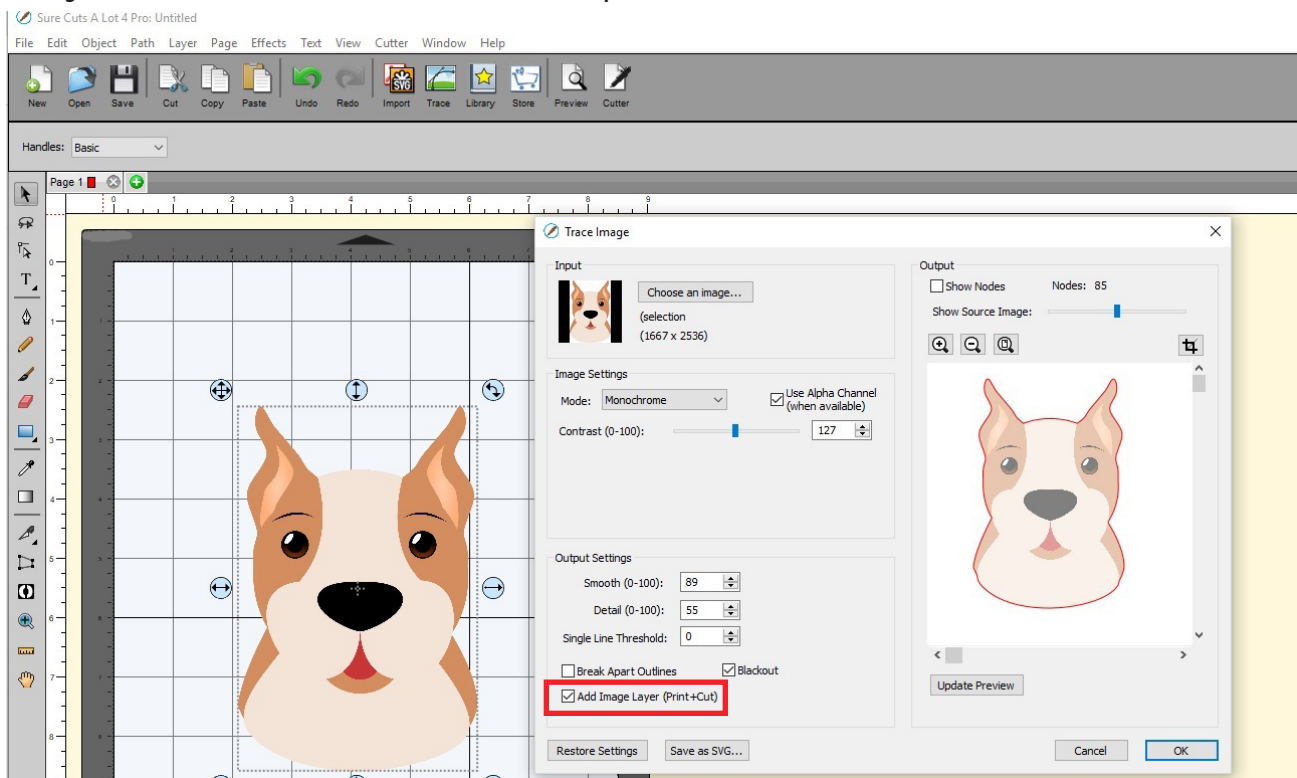

Optional (PNG): You can use File->Import and then select Effects->ShadowLayer which allows adjusting the distance of the outline. This is useful in cases where you are cutting stickers or when you want distance between the image and the cutline.

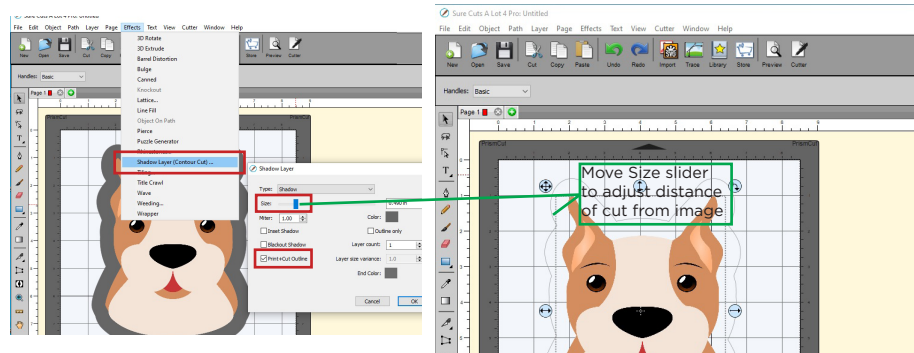

Click on Cutter and then select the Print&Cut option. This opens another window where you can click on Print to print your artwork with the contour marks.
IMPORTANT: PRINT AT ACTUAL SIZE (some printers resize to fit - this fails)

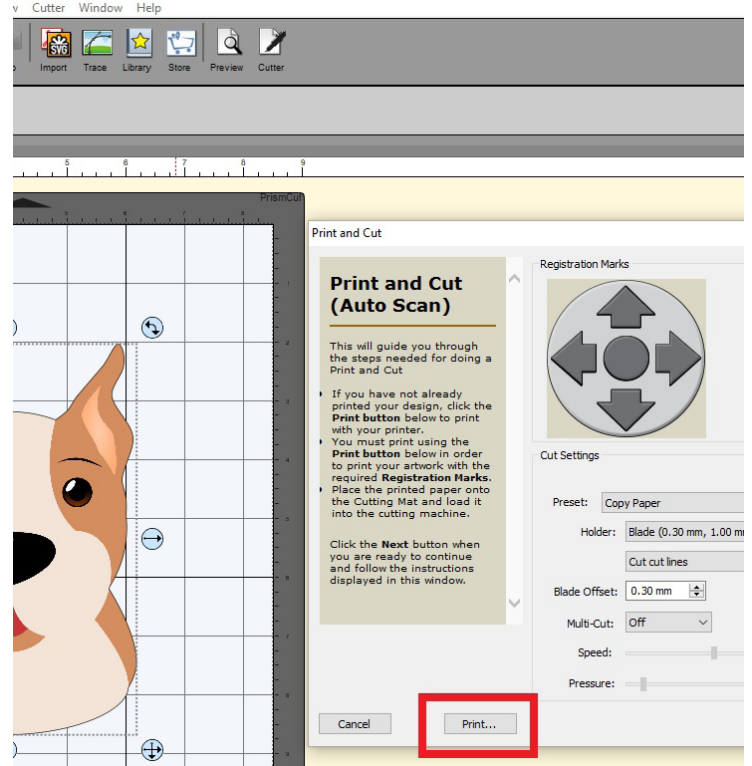
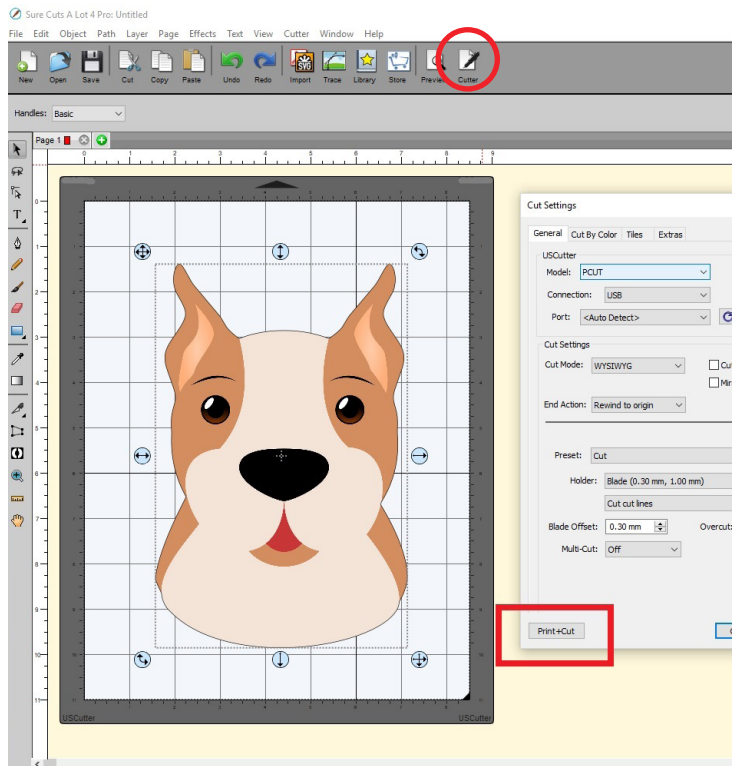

Place the printed artwork into the cutter so that the lower right registration mark is directly below where the blade would touch if pressed down.

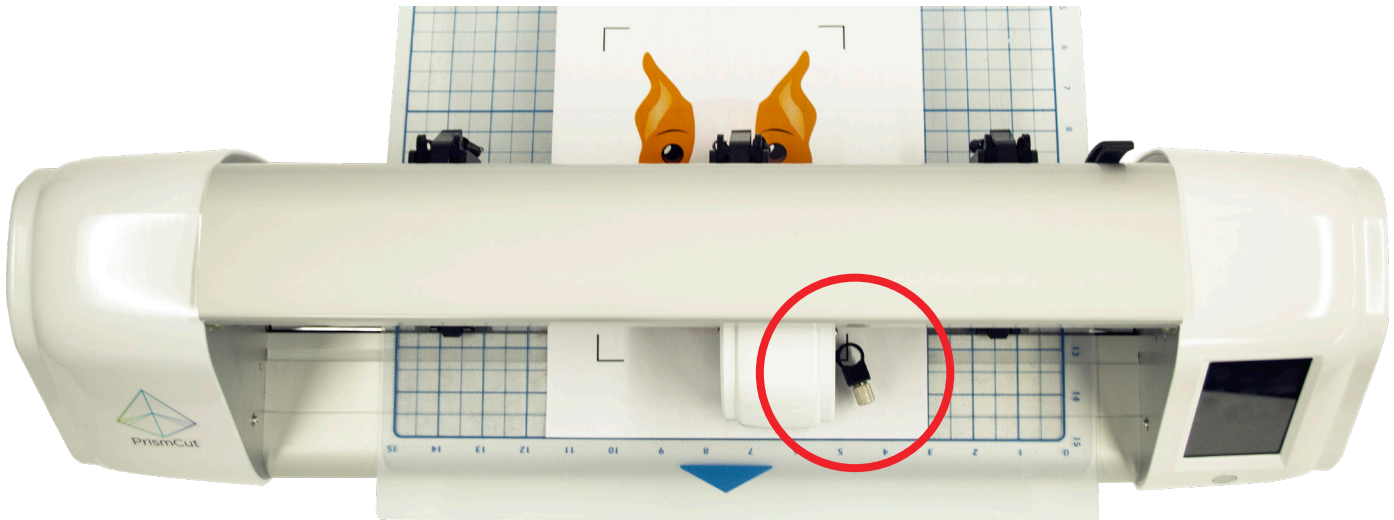

On your computer, press NEXT and then START. The camera will then inspect all 4 registration marks and then the cutter will cut along the contour lines.

Tip: Click the preview icon at the top of the PC screen to see what will actually be cut and what will be printed. This avoids unwanted surprises.

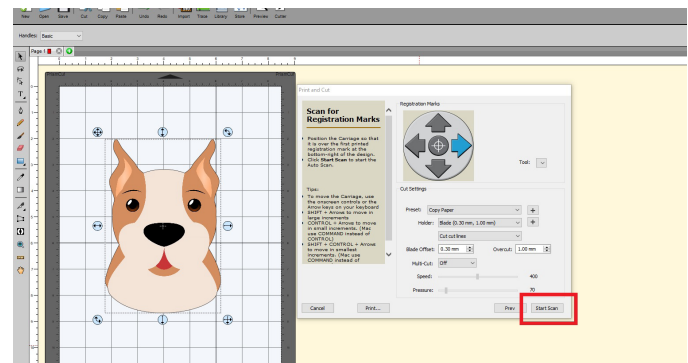

3.5.2 Contour Cutting / Print & Cut with VinylMaster (Windows PC)



To create a contour, open the Contour Cut Wizard by clicking on the apple icon at the top of the page. Next click the Build button to build a contour.

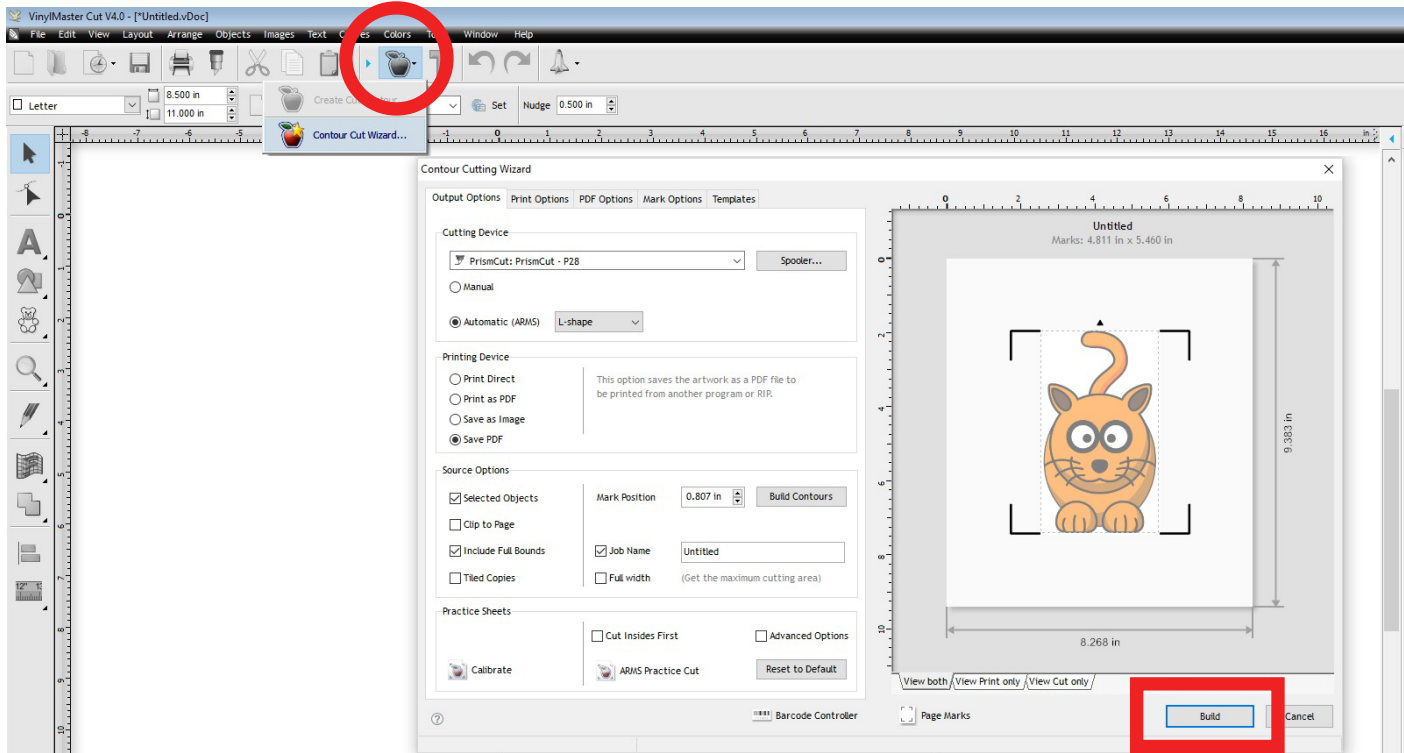

If you are using a photo, the software will ask to include auto-traced contours. For vector based artwork it will do this by itself. In any case, say Yes/Accept so that the software can Trace a contour around the outside of your image. The Trace settings allow you to adjust for poor contrast artwork. Note the “keep holes” checkbox which allows/denies contour cut lines inside the main outline.

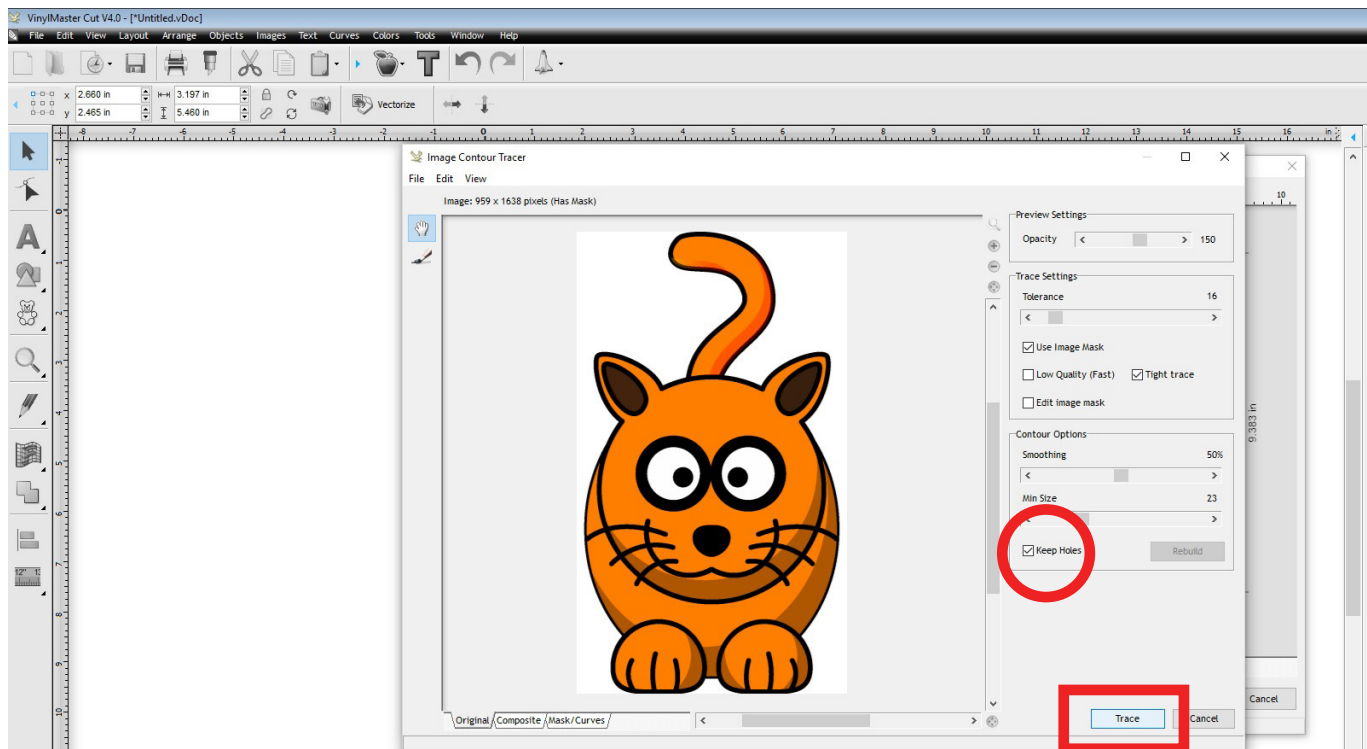

You can modify the space between the edge of your design and where the cut will be made by adjusting the Outline distance. Note that negative values are possible in case you want to eliminate any extra white space around the image.

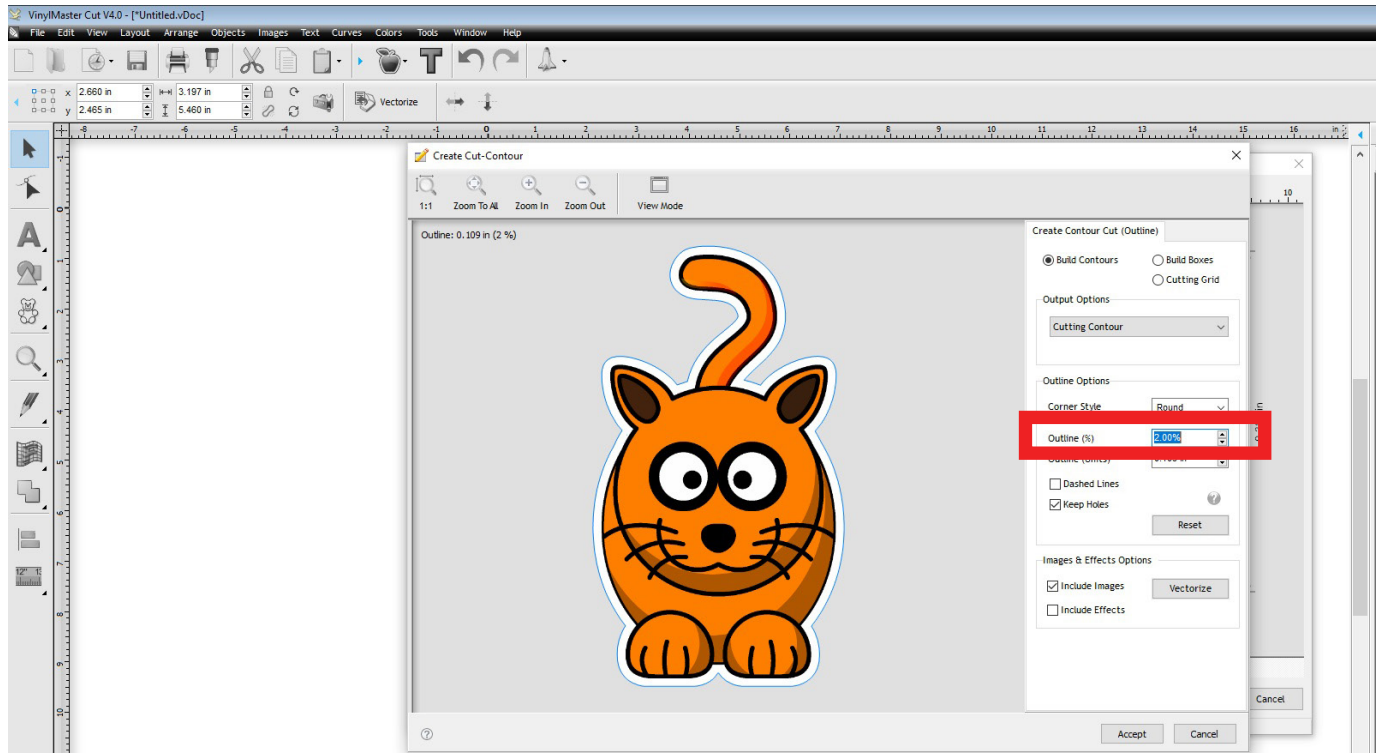

You can either print your design directly, or save to .PDF and print at a different location. The printed artwork will now have registration marks. Place the artwork in the cutter so that the cutter blade is directly above the registration mark in the lower right hand (as shown by the target icon in the below image). The cutter will then search for all registration marks, align itself and cut along the contour.

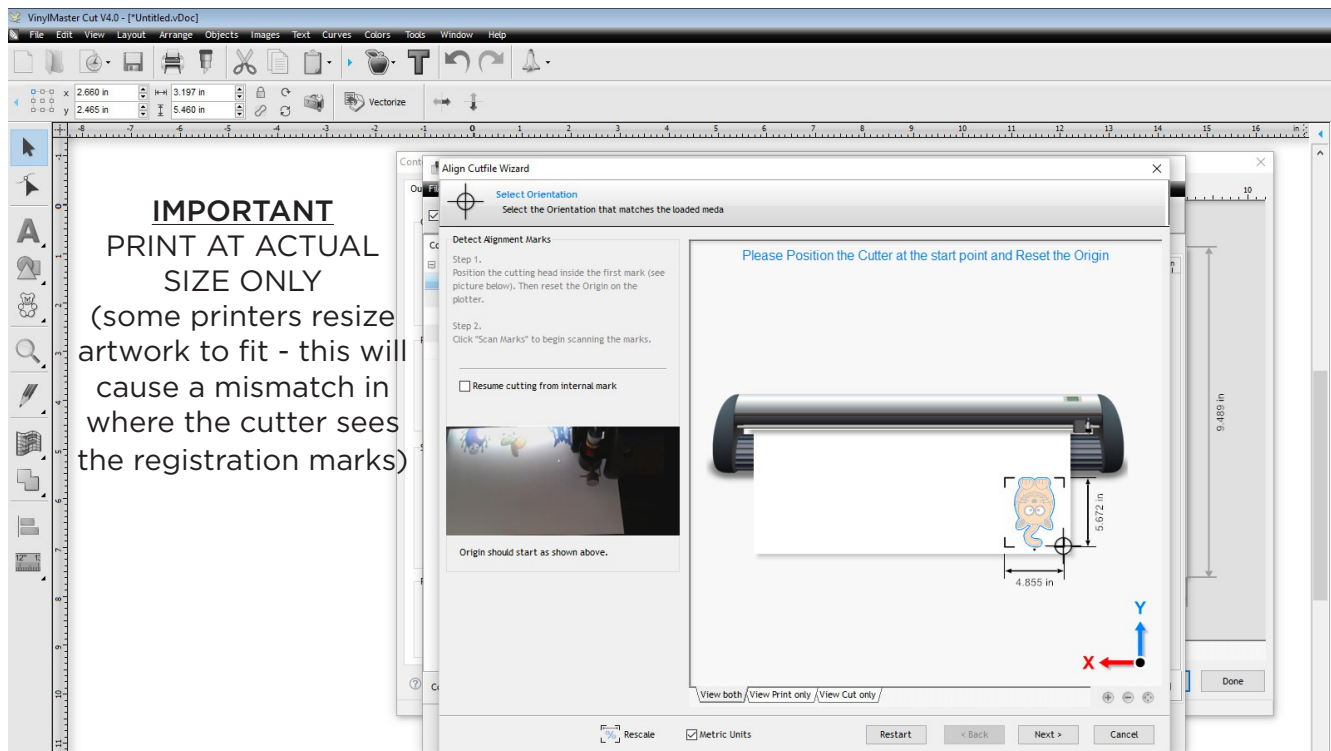

3.6 Using the (optional) embossing/scoring tool

If you choose to purchase the optional embossing tool, you can use it to make creases, or indents in cardstock and other thin malleable materials. Place the card stock on a surface with some “give” (felt, foam, rubber), so that it allows the back side of the card stock to become indented when pressed from above with the embossing tool. Turning the card over will show elevated/embossed lines where the tool has been used. The embossing tool can also be used to score creases when creating gift boxes where the sides fold up into a box.

To use the embossing tool, simply replace the blade holder with the embossing tool and set your software to use a blade offset and overcut of zero. Next adjust the speed and force to match the needs of the material being embossed. For card stock, a typical embossing speed setting is 200 and a typical value for force is 500. Note that the tool has two different sized heads allowing you to choose width of the score. Setting software to multiple passes allows a deeper mark.



3.7 Using the (optional) engraving tool

If you choose to purchase the optional engraving tool, you can use it to create scratches, or engravings into trophy plaques, dog tags, charm bracelets, plastic and soft metals. First, securely attach the material to be etched to the cutting mat using tape or adhesive so that the item does not move at all. Any movement will likely result in a failed etching.

Typical artwork uses diagonal lines within the design being etched, but other patterns can be used as well - whatever looks best to you. Setting the cutter software to use a lower speed and force with multiple passes allows you to etch away a little bit at a time if you are concerned about leaving pock marks. In your software, blade offset and overcut values should be set to zero when engraving.

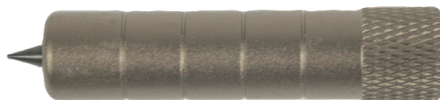

3.8 Using the (optional) laser tool

If you choose to purchase the optional laser tool, you can use it to laser etch leather, wood and other materials. It is critically important to full understand all safety related precautions that you need to know before considering using the laser attachment. Always wear protective lenses - even when aligning the laser before starting to cut, to be sure a reflection does not cause a stray beam to reach your eyes. The laser attachment fits on top of the carriage head and it is designed for use only in a well ventilated area.

Typical artwork uses diagonal lines when the design is being laser etched, but other patterns can be used as well - whatever looks best to you. The item to be laser etched should be securely fastened to the cutting mat with tape so that it does not move. Make sure that the artwork does not allow the laser to ever shine on the cutting mat. In your software, blade offset and overcut values should be set to zero

Using the laser tool requires passing a training course to receive the password to access the feature.

Note: Laser tool is not available in all regions

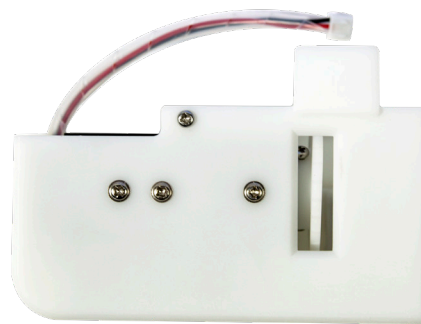

3.9 Connecting via Point-to-Point WiFi

In situations where there is no WiFi service available, as may be the case where you want to use your cutter at a street fair or in a remote location, it is possible to connect to your cutter in a Point-to-Point configuration. **Note that this will mean that your host computer is not able to connect wirelessly to the internet at the same time when using a Point-to-Point connection to the cutter.**

In the cutter's WiFi menu, delete (reset) any current WiFi settings and the cutter will display a value of HI-LINK_XXXX where the value of XXXX will be different for each cutter. The cutter now acts the same as your home router, but does not have an internet connection.

On your computer scan for available networks to find HI_LINK_XXXX and then connect to HI_LINK the same way that you would connect to your home router.

The password for Point-to-Point is 12345678

The IP address for Point-to-Point is 192.168.16.254

Section 4 - MAINTENANCE/TROUBLESHOOT

4.1 Care and Maintenance of Your Cutter

There is no need to oil or lubricate your cutter - simply keeping it clean should be enough to provide you with many years of service.

Keep the grit rollers and pinch rollers clean. The combination of pinch roller from above and grit roller from below is what makes your cutting mat or material move back and forth in a straight line. If one of these parts is greasy or sticky, you will see the material pull to one side, causing incorrect cutting.

At the same time, you want to be sure that the downward pressure of the pinch rollers is the same for every roller. Once again, this is to keep the material straight as it goes through the cutter. Note that the small levers on each pinch wheel should be in the down position except when extra pressure is needed.

Over time, your cutting strip (the white strip located directly below the path of the blade) may need to be replaced. Use a flathead screwdriver, putty knife or other flat blade instrument to pry out the old cutting strip from the groove in which it sits. You may also need to clean out any old glue or adhesive tape so that the new replacement strip sits completely flat in the groove. You can order a new cutting strip from your local PrismCut dealer.

Blades can get dull or chipped over time. In order to maintain precision cuts, it is recommended that you change to a fresh blade every 6 months, after any major use period or whenever the blade is dull, chipped or damaged.

4.2 Calibration

The most common calibration is for the RegMarkCamera. This involves making sure that the exact distance between the camera lens and the blade is known to the cutter.

You need to be in the Advanced Menu to perform calibration

Note that the tip of the pen has a small cap that needs to be removed if using it for the first time

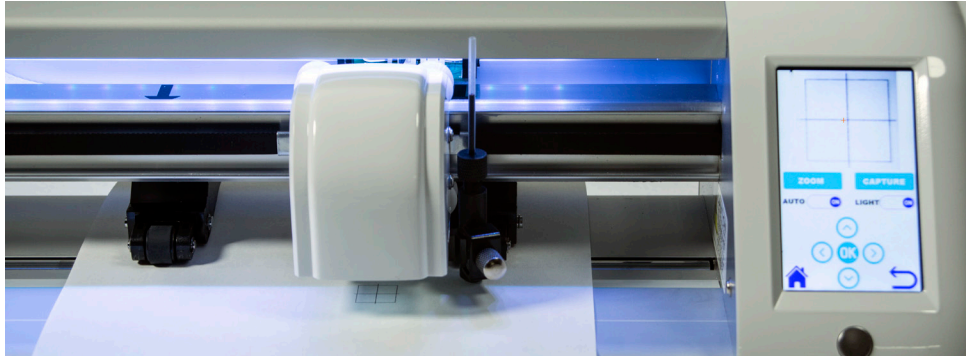

- 1) Remove the blade holder and replace with a pen.
- 2) Insert a piece of plain white paper and position the pen over the paper
- 3) Select SETTINGS->ADVANCED->REGMARKCAMERA->CALIBRATION
- 4) Under CALIBRATION, select REGMARKCAMERA and press START

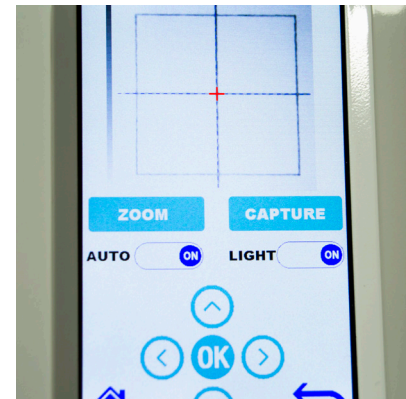
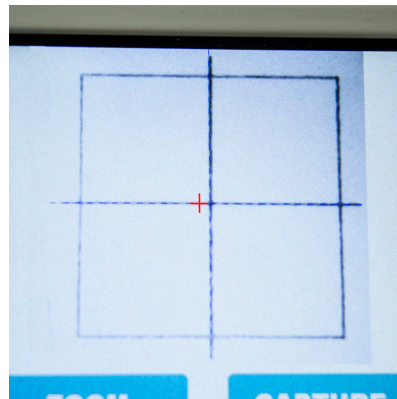

- 5) The cutter will then draw a square on the paper and take a picture of it.
- 6) Use the arrow keys to move the red cross to match the center of the square.
- 7) Press OK and the cutter will take another picture to show closer alignment.
- 8) Repeat the process until the red cross matches the center of the square.

CAUTION: Calibrating other functions such as SCALE and OFFSET will erase factory calibrations and should only be made under the guidance of a qualified technician.

RECOMMENDED CUTTER SETTINGS

Below items cut within material thickness limits of 2 mm and density of approx 1 g/cm³
 Note that thicker materials may need multiple repeat passes to cut all the way through.

MATERIAL	SPEED	FORCE	BLADE
Heat Transfer Vinyl	400	70	45°
Pressure Sensitive Vinyl	400	70	45°
Stencil Material	350	160	45°
Paper (75 gsm)	200	50	45°
Labels/Decals	500	80	45°
Cardstock (160 gsm)	500	500	45°
Icing Sheets	250	160	60°
Shrink Film	300	250	60°
Wood Veneer	200	450*	60°
Magnetic Sheets (thin)	200	600*	60°
Rhinestone Templates	200	600*	60°
Foils	200	100	60°
Posterboard (250 gsm)	350	500*	60°
EVA Foam	300	100*	60°
Mylar	300	450*	60°
Thin Chipboard	200	500*	60°
Paint Mask	350	200	60°
Styrene	450	400	60°
Leather	100	750	60°
Felt	200	300*	30°
Denim	100	750*	30°
Cotton	250	350	30°
Wool	250	750	30°
* force settings with an asterisk may need multiple passes			

The above settings should be considered as starting points and may need to be modified depending on the characteristics of the specific brand and nature of material you are using.

When considering how to cut a material that you are encountering for the first time, look at the thickness vs. density of the material. Materials with a high density will typically need more force and a slower speed. In cases where the material is thicker, multiple passes is often a good place to start before increasing force. You may also need to raise the blade holder so that it sits higher in the jaw when cutting thicker materials to allow the blade some distance to drop. If there is no distance between blade and material, the downforce can be compromised. Thin materials, and especially fabrics are best addressed with a 30° blade. Fabrics often require the use of starch or backing material to stiffen the fabric before cutting and/or using a brayer roller to get the fabric to stick and lay flat on the sticky part of the cutting mat.

4.3 Troubleshooting cutter issues

Before contacting support, you may want to try basic troubleshooting.

1) Unit will not power on.

- Make sure power cord is securely plugged into the power adapter.
- The power adaptor shows a small green light when it is working correctly
- Check the exact outlet you are using by plugging in a lamp. Note that sometimes the bottom outlet in a two outlet wall plate is controlled by a light switch.

2) The mat/vinyl pulls to one side when it goes through the cutter

- Proper alignment when placing the mat/vinyl in the cutter is most important
- Also, make sure the pinch rollers are directly under the black arrows
- Make sure the grit rollers on the bottom bar are clean of any sticky residue
- Place your mat/vinyl so that the pinch rollers are near the outside edges (note that pinch rollers must **always** match up with grit rollers below)
- You may have better results by adding (or removing) a middle pinch roller
- Make sure the small levers on the back of pinch rollers are all down (or all up)
- You might be using too much downforce on the blade. Increase passes instead

3) The blade does not cut all the way through the material

- Some materials need multiple passes to cut all the way through (set in SW)
- Check that blade offset and overcut settings are set correctly in software
- Try increasing pressure before considering extending exposed blade length

4) Cutter stops/stalls when cutting very thick materials

- Try decreasing speed/force and increasing number of passes
- Place the bladeholder in the jaw slightly higher to allow blade to drop more

5) I cannot get WiFi to connect

- Make sure that the home screen does **NOT** say HI_LINK_XXXX
- Make sure the home screen shows the IP address of your home/office router (typical home IP addresses may start with 192.xxx or 172.xxx or 10.xxx)
- The IP address on the cutter and in the software **MUST** be the same
- Check that you are using the correct WiFi password for your home router
- In WiFi menu press/hold RESET for 3 seconds, then rescan from blank setup

6) I cannot get USB to connect

- Note that USB is not needed if you are using WiFi
- Test the USB port on the computer with a different USB device
- Make sure the connection settings on your computer show USB in the software
- With computer on, remove and re-insert the USB cable to re-initialize the port

7) The camera does not see the registration marks when contour cutting

- The camera may need calibration, please see section 4.2 for the procedure
- Turning the camera light on/off may help the contrast at the edge of the mark
- Turning the room lights off or moving the cutter to a less bright area may help
- Make sure the registration marks have printed solidly with no missing ink areas
- Make sure your printer is set to print at “actual size” or it will not work
- Make sure that the printed artwork file matches the contour cutting file
- Ensure that the printed design is placed in the cutter as straight as possible
- Position the blade over the lower right registration mark just outside the mark

8) My cuts show tearing

- Check to see that your blade is not exposed more than 1/2 credit card thickness
- Try reducing the down force. Too much force can impede material movement.
- Blade may be chipped or dull and needs to be replaced

9) The corners of my cuts are not cutting completely

- Check to see that you have the correct overcut setting in your software
- A typical overcut setting is 1 mm but may be more/less for different blades
- When using the pen, etching tool or engraving tool overcut will be zero

10) I do not see PrismCut as a pull down menu option in Sure Cuts A Lot

- This is likely due to not having the PrismCut Driver installed
- For Sure Cuts A Lot 4 Pro, make sure you have version 4.080 or later installed

11) I do not see PrismCut as a pull down menu option in VinylMaster

- This is likely due to not having the PrismCut driver installed
- On the top line of VinylMaster software select Help->About to see your PSN
- Go to <https://fcws1.com/info/vmlinks.php> and select Download Software
- Input your Vinylmaster PSN to allow download (or click the Don't Know link)
- Re-install the software and select PrismCut as the cutter during install.

12) How do I manually install the PrismCut driver for VinylMaster

- On the top line of VinylMaster software select Help->About to see your PSN
- Go to <https://fcws1.com/info/vmlinks.php> and select Legacy Drivers
- Input your Vinylmaster PSN into the legacy Drivers page to see drivers list
- Download the PrismCut driver to a known location on your computer
- In VinylMaster, open the Spooler and select Cutter->Install_Cutter_Driver
- You should now be able to ADD the PrismCut in the Spooler->Connection

4.4 Warranty and Support -

PrismCut comes with a limited 1 year warranty as provided by your dealer.

In the USA, your warranty and support are provided by:



USCutter offers a limited 1 year warranty on this cutter.

Details of our standard warranty policy can be viewed on-line at the following link:

www.uscutter.com/Warranty-And>Returns-Policy

For support for your equipment, contact USCutter at:
Sales & Support: 1-425-481-3555 M-F 7:30-11:30am, 12:30-4pm PST
support.uscutter.com

